



10Gbps XFP Optical Transceiver

RTXM226-440

Features

- *Compliant with XFP MSA Rev.4.0*
- *Data Rate from 9.95 Gbps to 11.3Gbps*
- *1550nm EML transmitter and PIN receiver*
- *Industry-standard, protocol-independent XFI interface*
- *Transmission distance up to 40km*
- *LC duplex receptacle package*
- *Low power dissipation (Max 3.5W)*
- *Hot Pluggable*
- *Built in digital diagnostic Functions*
- *Operating case temperature range:0°C~70°C*
- *RoHS compliant*

Application

- *SONET OC-192&SDH STM 64*
- *10Gigabit Ethernet*
- *10Gigabit Fiber Channel*

Absolute Maximum Ratings

Parameter	Symbol	Unit	Min	Max
Supply Voltage 1	Vcc3	V	-0.5	4.0
Supply Voltage 2	Vcc5	V	-0.5	6.0
Storage Temperature	Ts	°C	-40	85
Operating Case Temperature	Tc	°C	0	70
Relative humidity (Non condensation)	-	%	5	90

Recommended Operating Conditions

Parameter	Symbol	Unit	Min	Typ	Max
Operating Case Temperature	TC	°C	0	-	70
Supply Voltage 1	VCC3	V	3.13	3.3	3.47
Supply Current 1	ICC3	mA	-	-	750
Supply Voltage 2	VCC5	V	4.75	5.0	5.25
Supply Current 2	ICC5	mA	-	-	500
Power Dissipation	-	W	-	-	3.5

Electrical Characteristics

(Tested under recommended operating conditions, unless otherwise noted)

Parameter	Symbol	Unit	Min	Typ	Max	Note
Transmitter						
Input differential impedance	Rin	Ω	-	100	-	
Differential data input swing	Vin,pp	mV	120	-	1000	
Transmit Disable Voltage	VD	V	2.0	-	Vcc3+0.3	
Transmit Enable Voltage	VEN	V	0	-	+0.8	
Transmit Disable Assert Time	-	us	-	-	10	
Receiver						
Differential data output swing	Vout,pp	mV	400	650	800	
Data output rise time	Tr	ps	24	-	-	
Data output fall time	Tf	ps	24	-	-	
LOS Fault	-	V	2	-	Vdd3+0.3	1
LOS Normal	-	V	0	-	+0.8	

Note1: Vdd3 is host +3.3V power supply.

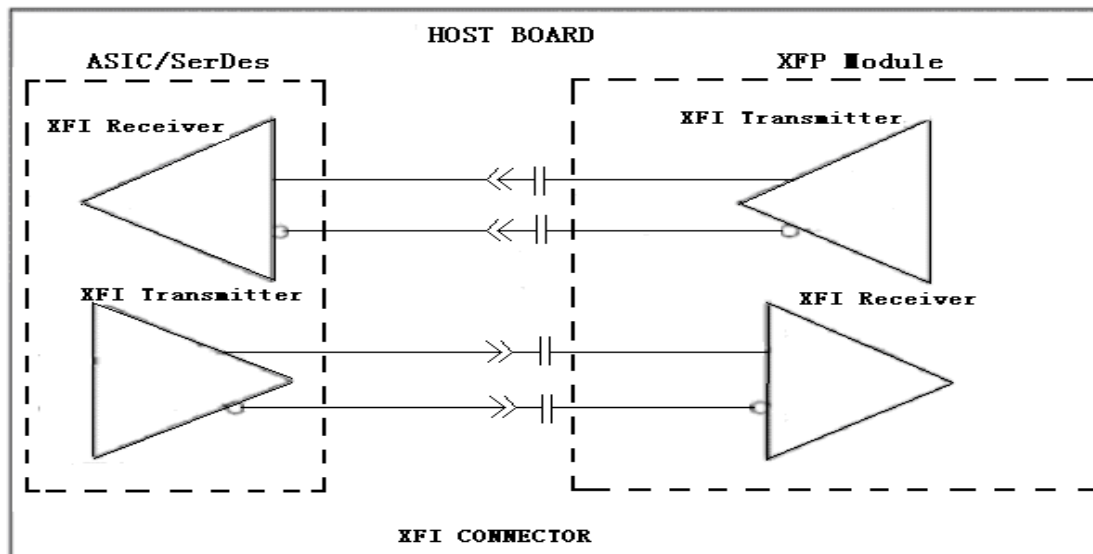

Figure 1 High Speed Electrical Interface

Low Speed Electrical Interface

Parameter	Symbol	Unit	Min	Max	Note
LVTTTL-I (Tx_Dis,P_Down/RST)	V _{IH}	V	2.0	V _{cc3} +0.3	
	V _{IL}	V	-0.3	0.8	
LVTTTL-O (Interrupt,Mod_NR,Rx_Los)	V _{OH}	V	V _{dd3} -0.5	V _{dd3} +0.3	1
	V _{OL}	V	0.0	0.4	
LVTTTL-I (9SCL,SDA)	V _{IH}	V	V _{dd3} *0.7	V _{dd3} +0.5	
	V _{IL}	V	-0.3	V _{dd3} *0.3	1
LVTTTL-O (SCL,SDA)	V _{OH}	V	V _{dd3} -0.5	V _{dd3} +0.3	
	V _{OL}	V	0.0	0.4	
Leakage Current	I _L	μA	-10	10	
I2C Clock Rate		KHz		400	

Note1: V_{dd3} is host +3.3V power supply.

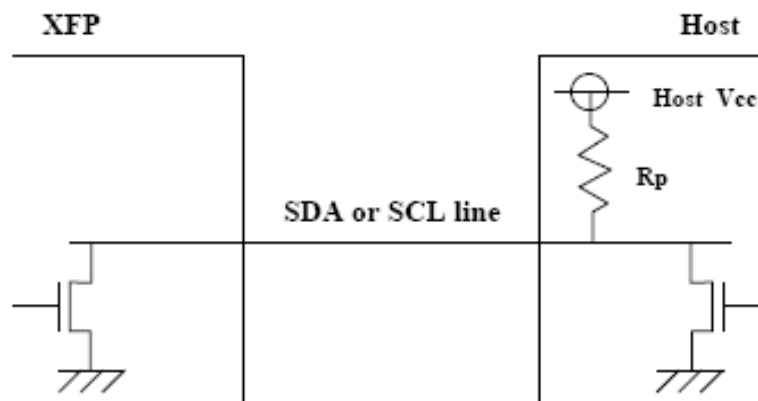

Figure 2 Open Drain Type Connection for I2C

Optical Characteristics

(Tested under recommended operating conditions, unless otherwise noted)

Parameter	Symbol	Unit	Min	Typ	Max	Note
Optical transmitter Characteristics						
Data rate	-	Gbps	9.95	-	11.3	
Optical Power	Po	dBm	-1.0	-	2	ITU-T G.691
Center Wavelength range	λ	nm	1530	1550	1565	
Extinction Ratio	ER	dB	8.2	-	-	ITU-T G.691
Spectral width	-	nm	-	-	1	-20dB
SMSR	-	dB	30	-	-	
Eye diagram	Compliant with ITU-T G.691 STM-64 eye mask					
Dispersion penalty		dB	-	-	2	50KmSMF
Optical receive Characteristics						
Data rate	-	Gbps	9.95	-	11.3	
Receiver Sensitivity	-	dBm	-	-	-16	ER=8.2
Overload	-	dBm	-1	-	-	
Optical Return Loss	-	dB	27	-	-	
LOS De-Assert	-	dBm	-	-	-20	
LOS Assert	-	dBm	-27	-	-	
LOS Hysteresis	-	dB	0.5	-	6	

Block Diagram

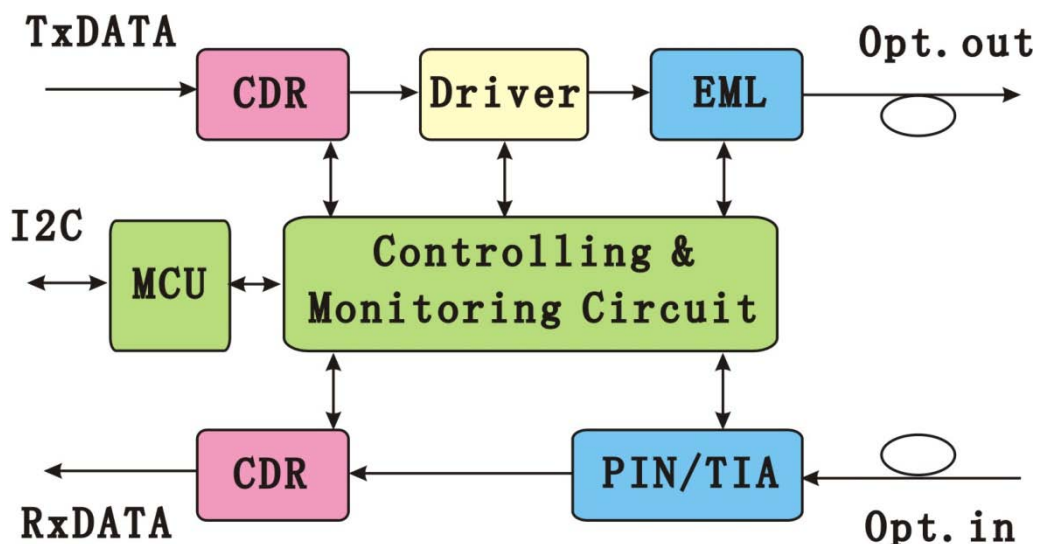

Figure 3 Block Diagram for RTX226-440

Pin Description

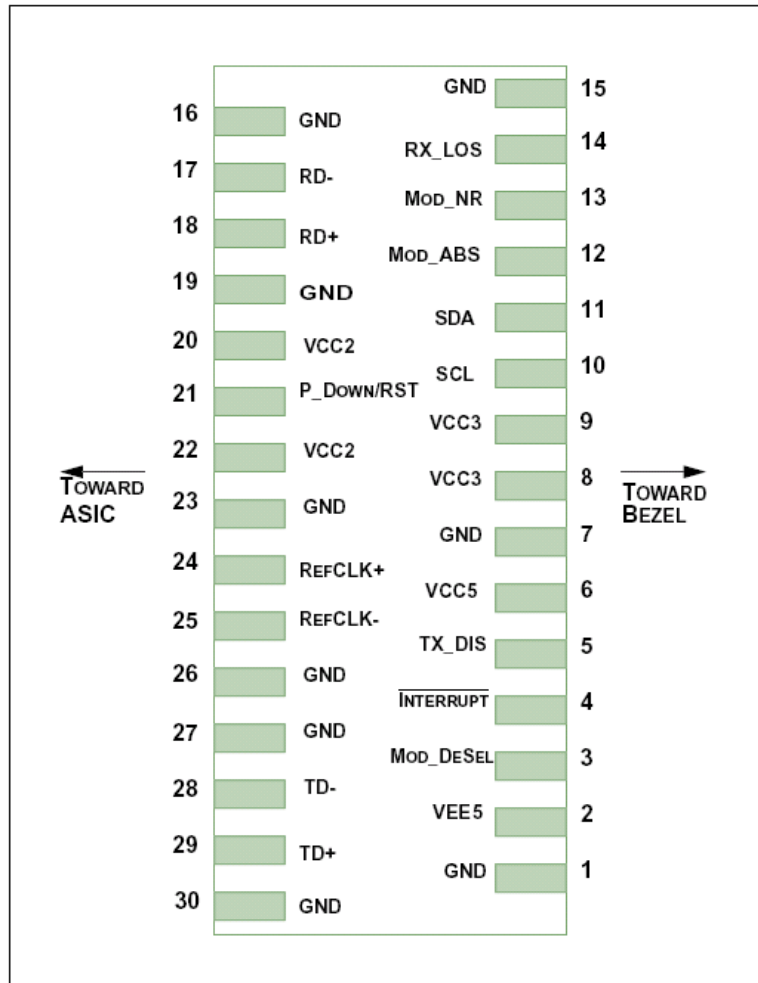

Figure 4 Host PCB XFP Pinout Top View

Module Electrical Pin Definition

Pin	Logic	Symbol	Name/Description	Note
1		GND	Module Ground	1
2		VEE5	Optional -5.2V Power Supply (Not Required)	
3	LVTTTL-I	Mod_DeSel	Module De-select; When held low allows module to respond to 2-wire serial interface	
4	LVTTTL-O	Interrupt	Interrupt; Indicates presence of an important condition which can be read over the 2-wire serial interface	2
5	LVTTTL-I	TX_DIS	Transmitter Disable; Turns off transmitter laser output	
6		VCC5	+5V Power Supply	
7		GND	Module Ground	1
8		VCC3	+3.3V Power Supply	
9		VCC3	+3.3V Power Supply	

10	LVTTTL-I/O	SCL	2-Wire Serial Interface Clock	2
11	LVTTTL-I/O	SDA	2-Wire Serial Interface Data Line	2
12	LVTTTL-O	Mod_Abs	Indicates Module is not present. Grounded in the Module	2
13	LVTTTL-O	Mod_NR	Module Not Ready; Indicating Module Operational Fault	2
14	LVTTTL-O	RX_LOS	Receiver Loss Of Signal Indicator	2
15		GND	Module Ground	1
16		GND	Module Ground	1
17	CML-O	RD-	Receiver Inverted Data Output	
18	CML-O	RD+	Receiver Non-Inverted Data Output	
19		GND	Module Ground	1
20		VCC2	+1.8V Power Supply (Not Required)	
21	LVTTTL-I	P_Down/RST	Power down; When high, requires the module to limit power consumption to 1.5W or below. 2-Wire serial interface must be functional in the low power mode. Reset; The falling edge initiates a complete reset of the module including the 2-wire serial interface, equivalent to a power cycle.	
22		VCC2	+1.8V Power Supply (Not Required)	
23		GND	Module Ground	1
24	PECL-I	RefCLK+	Reference Clock Non-Inverted Input, AC coupled on the host board (Not Required)	
25	PECL-I	RefCLK-	Reference Clock Inverted Input, AC coupled on the host board (Not Required)	
26		GND	Module Ground	1
27		GND	Module Ground	1
28	CML-I	TD-	Transmitter Inverted Data Input	
29	CML-I	TD+	Transmitter Non-Inverted Data Input	
30		GND	Module Ground	1

Note1: Module ground pins GND are isolated from the module case and chassis ground within the module.

Note2: Shall be pulled up with 4.7K-10Kohms to a voltage between 3.15V and 3.45V on the host board.

Digital Diagnostic Functions

As defined by the XFP MSA, digital diagnostic functions are provided via a 2-wire serial interface, which allows real-time access to the following operating parameters:

Transceiver Temperature

Tx Bias Current

Tx Optical Power

RX Received Optical Power

Transceiver +5.0V Supply Voltage

Typical Application Circuit For Power Supply

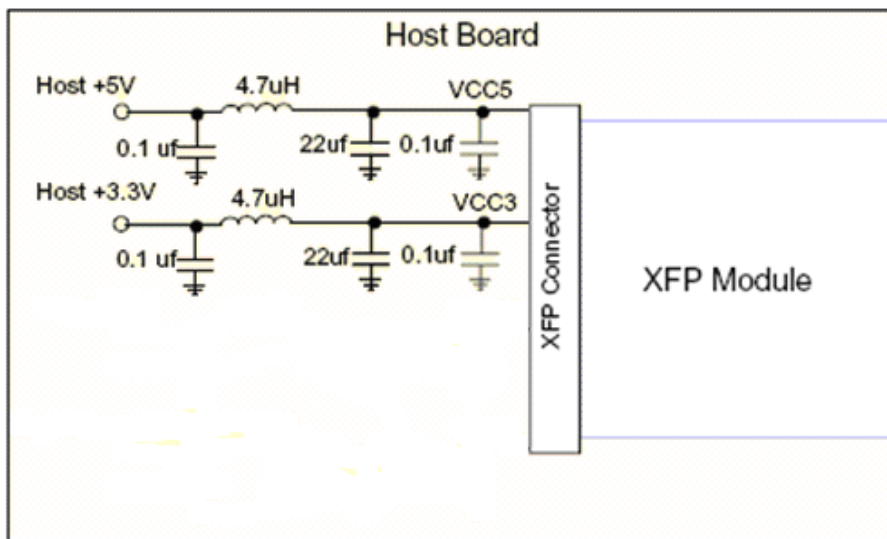

Figure 5 Example of Host Board Supply Filtering Network

Package Outline

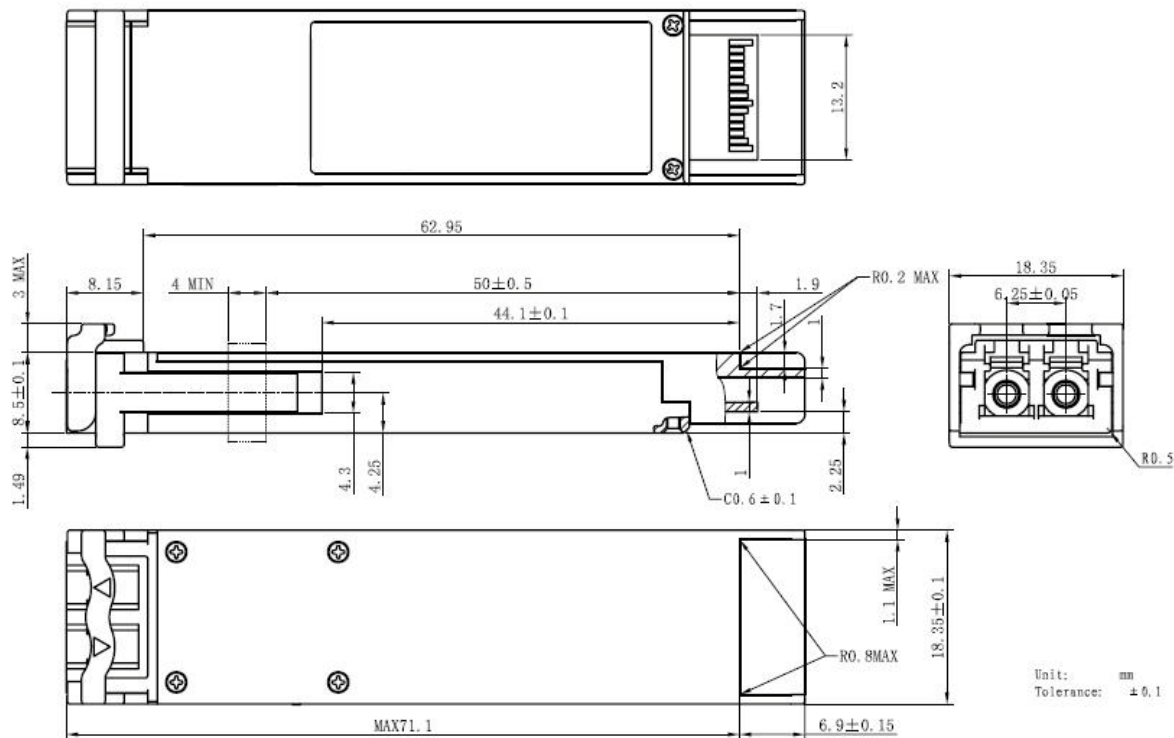

Figure 6 Package Outline

Regulatory Compliance

Feature	Test Method	Performance
Laser Eye Safety	FDA 21 CFR 1040.10 and 1040.11 IEC 60825-1: 1994+ A11: 1996+ A2: 2001 IEC 60825-2: 2004 + A1: 2006 EN 60825-1:1994+A1:2002+A2:2001 EN 60825-2: 2004	Compliant with Class 1 laser product
Electrostatic Discharge (ESD) to the Electrical Pins	MIL-STD-883E Method 3015.7 Human Body Model	Class 1 (>1.5kV)
Electrostatic Discharge (ESD) Immunity	IEC 61000-4-2: 2001	Class 2 (>4.0kV)
Electromagnetic Interference (EMI)	FCC Part 15 Subpart J Class B CISPR22: 1997+A1: 2000+A2: 2002, Class B EN55022: 1998+A1: 2000+A2: 2003, Class B	Compliant with standards

Ordering Information

Part No.	Specification							Application
	Package	Data rate	Laser	Optical Power	Detector	Sensitivity	Temp Reach	
RTXM226-440	XFP	9.95G ~11.3G	1550nm DFB	-1 ~ 2dBm	PIN	-16dBm(Max)	0~70oC 40km	SONET OC-192 IR-2 SDH STM S-64.2, 10GBASE-ER 10G Fiber Channel

WTD reserves the right to make changes to the product(s) or information contained herein without notice. No liability is assumed as a result of their use or application. No rights under any patent accompany the sale of any such product(s) or information.

Edition 2009-12-01

Published by Wuhan Telecommunication Devices Co.,Ltd.

Copyright © WTD

All Rights Reserved.