



10Gigabit XFP Optical Transceiver

RTXM226-408

Features

- *Compliant with XFP MSA*
- *Data Rate from 9.95 Gbps to 11.3Gbps*
- *1310nm DFB TOSA and PIN ROSA*
- *Industry-standard, protocol-independent, XFI interface*
- *Transmission distance up to 10km*
- *LC duplex receptacle package*
- *Single +3.3V Power Supply*
- *Hot Pluggable*
- *Built in digital diagnostic Functions*
- *Operating case temperature range:0°C~70°C*
- *RoHS compliant*

Application

- *SONET OC-192 SR-1&SDH STM I-64.1*
- *10GBASE-LR/LW 10Gigabit Ethernet*
- *1200-SM-LL-L 10Gigabit Fiber Channel*

Absolute Maximum Ratings

Table 1 Maximum operation conditions

Parameter	Symbol	Unit	Min	Max
Supply Voltage	V_{CC3}	V	-0.5	4.0
Storage Temperature	T_s	°C	-40	85
Operating Case Temperature	T_c	°C	0	70
Relative humidity (Non condensation)	-	%	5	90

Recommended Operating Conditions

Table 2 Recommended Operating Conditions

Parameter	Symbol	Unit	Min	Typ	Max
Operating Case Temperature	T_c	°C	0	-	70
Supply Voltage	V_{CC3}	V	3.13	3.3	3.47
Supply Current	I_{CC3}	mA	-	-	650
Power Dissipation	-	W	-	1.7	2.3

Electrical Characteristics

(Tested under recommended operating conditions, unless otherwise noted)

Table 3 High Speed Electrical Interface

Parameter	Symbol	Unit	Min	Typ	Max	Note
Transmitter						
Input differential impedance	R_{in}	Ω	-	100	-	
Differential data input swing	$V_{in,pp}$	mV	120	-	1000	
Transmit Disable Voltage	VD	V	2.0	-	V_{CC3}	
Transmit Enable Voltage	VEN	V	0	-	+0.8	
Transmit Disable Assert Time	-	us	-	-	10	
Receiver						
Differential data output swing	$V_{out,pp}$	mV	400	-	800	
Data output rise time	T_r	ps	24	-	-	
Data output fall time	T_f	ps	24	-	-	
LOS Fault	-	V	$V_{dd3}-0.5$	-	V_{dd3}	1
LOS Normal	-	V	0	-	+0.5	

Note1: V_{dd3} is host +3.3V power supply.

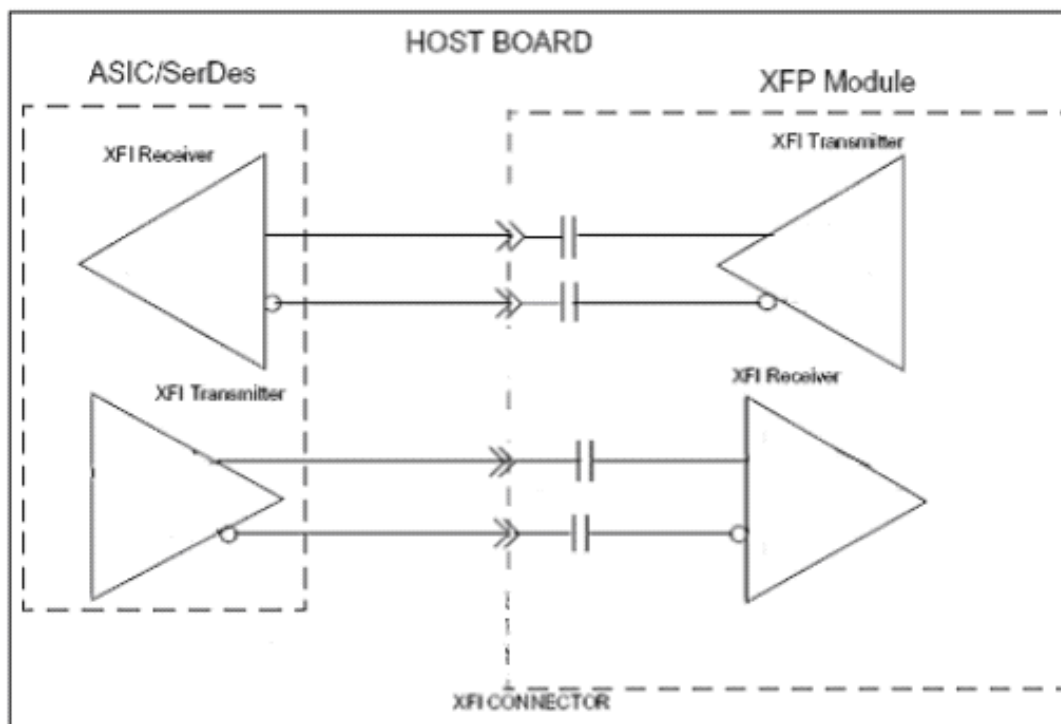

Figure 1 High Speed Electrical Interface

Table 4 Low Speed Electrical Interface

Parameter	Symbol	Unit	Min	Max	Note
LVTTL-I	V_{IH}	V	2.0	$V_{CC3} + 0.3$	
(Tx_Dis,P_Down/RST)	V_{IL}	V	-0.3	0.8	
LVTTL-O	V_{OH}	V	$V_{dd3} - 0.5$	$V_{dd3} + 0.3$	1
(Interrupt,Mod_NR,Rx_Los)	V_{OL}	V	0.0	0.4	
LVTTL-I	V_{IH}	V	$V_{dd3} * 0.7$	$V_{dd3} + 0.5$	1
(SCL,SDA)	V_{IL}	V	-0.3	$V_{dd3} * 0.3$	
LVTTL-O	V_{OH}	V	$V_{dd3} - 0.5$	$V_{dd3} + 0.3$	
(SCL,SDA)	V_{OL}	V	0.0	0.4	
Leakage Current	I_L	μA	-10	10	
I ² C Clock Rate		KHz		400	

Note1: V_{dd3} is host +3.3V power supply.

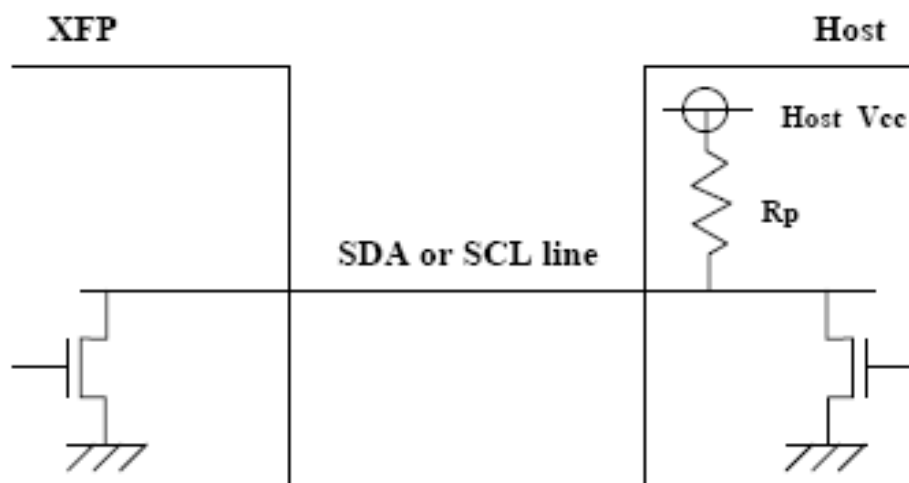

Figure 2 Open Drain Type Connection for I²C

Optical Characteristics

(Tested under recommended operating conditions, unless otherwise noted)

Table 5 Optical Characteristics

Parameter	Symbol	Unit	Min	Typ	Max	Note
Optical transmitter Characteristics						
Data rate	-	Gbps	9.95	-	11.3	
Optical Power	P _o	dBm	-6	-	-1	
Center Wavelength range	λ	nm	1290	-	1330	
Extinction Ratio	ER	dB	6	-	-	
Spectral width	-	nm	-	-	1	
SMSR	-	dB	30	-	-	
Eye diagram	Compliant with ITU-T G.691 eye mask and IEEE802.3ae eye mask					
Dispersion penalty		dB	-	-	1	1
Optical receive Characteristics						
Data rate	-	Gbps	9.95	-	11.3	
Receiver Sensitivity	-	dBm	-	-	-14	2
Overload	-	dBm	0.5	-	-	2
Optical Return Loss	-	dB	27	-	-	
LOS De-Assert	-	dBm	-18	-	-	2
LOS Assert	-	dBm	-	-	-22	2
LOS Hysteresis	-	dB	0.5	-	6	2

Note1: With 10km G.652 SMF

Note2: Ber < 10⁻¹², 2³¹-1PRBS NRZ, 1310nm, ER=6dB

Block Diagram

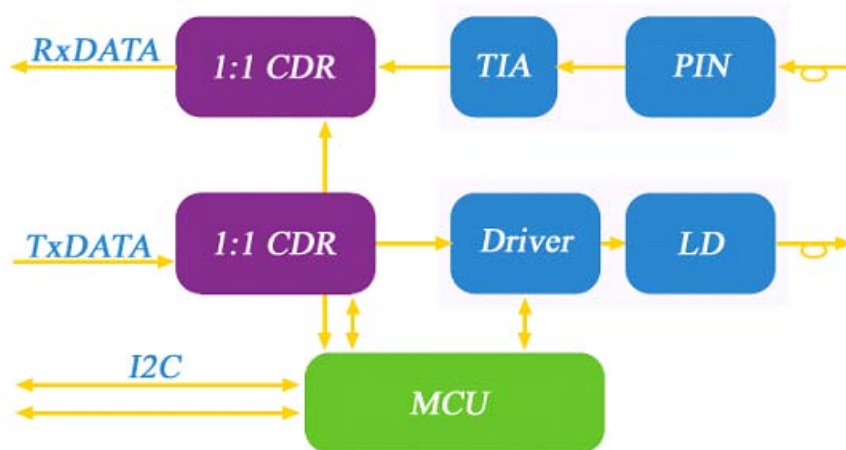

Figure 3 Block Diagram

Pin Description

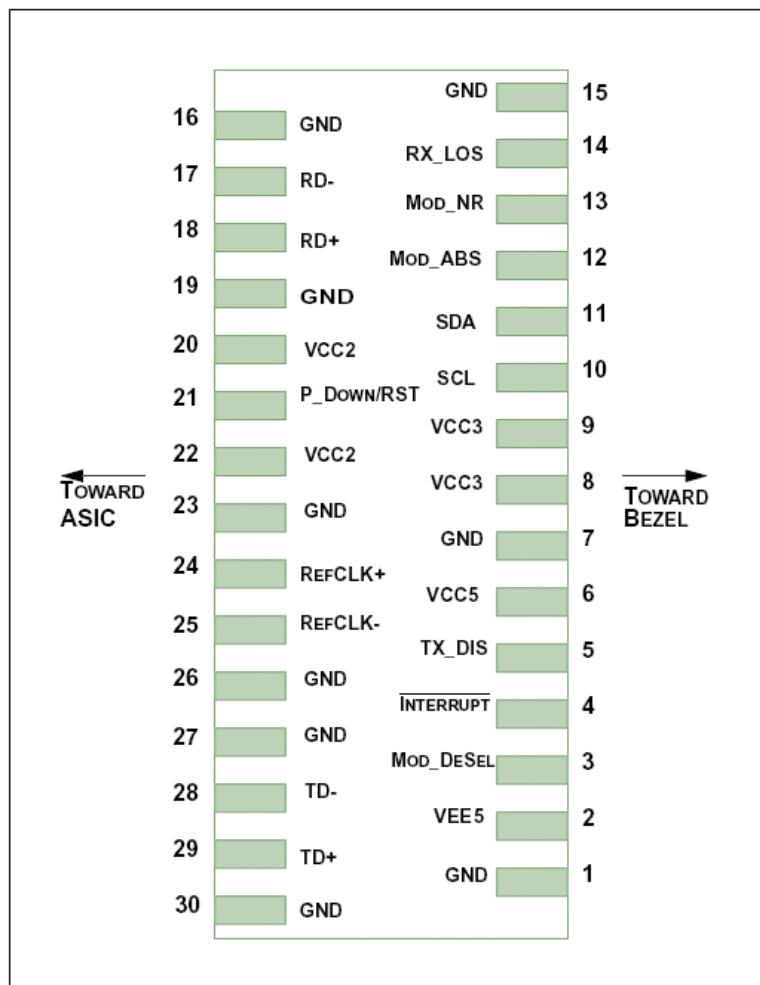

Figure 4 Host PCB XFP Pinout Top View

Table 6 Module Electrical Pin Definition

Pin	Logic	Symbol	Name/Description	Note
1		GND	Module Ground	1
2		VEE5	Optional -5.2V Power Supply (<i>Not Required</i>)	
3	LVTTTL-I	Mod_DeSel	Module De-select; When held low allows module to respond to 2-wire serial interface	
4	LVTTTL-O	Interrupt	Interrupt; Indicates presence of an important condition which can be read over the 2-wire serial interface	2
5	LVTTTL-I	TX_DIS	Transmitter Disable; Turns off transmitter laser output	
6		VCC5	+5V Power Supply (<i>Not Required</i>)	
7		GND	Module Ground	1
8		VCC3	+3.3V Power Supply	
9		VCC3	+3.3V Power Supply	
10	LVTTTL-I/O	SCL	2-Wire Serial Interface Clock	2
11	LVTTTL-I/O	SDA	2-Wire Serial Interface Data Line	2
12	LVTTTL-O	Mod_Abs	Indicates Module is not present. Grounded in the Module	2
13	LVTTTL-O	Mod_NR	Module Not Ready; Indicating Module Operational Fault	2
14	LVTTTL-O	RX_LOS	Receiver Loss Of Signal Indicator	2
15		GND	Module Ground	1
16		GND	Module Ground	1
17	CML-O	RD-	Receiver Inverted Data Output	
18	CML-O	RD+	Receiver Non-Inverted Data Output	
19		GND	Module Ground	1
20		VCC2	+1.8V Power Supply (<i>Not Required</i>)	
21	LVTTTL-I	P_Down/RST	Power down; When high, requires the module to limit power consumption to 1.5W or below. 2-Wire serial interface must be functional in the low power mode. Reset; The falling edge initiates a complete reset of the module including the 2-wire serial interface, equivalent to a power cycle.	
22		VCC2	+1.8V Power Supply (<i>Not Required</i>)	
23		GND	Module Ground	1
24	PECL-I	RefCLK+	Reference Clock Non-Inverted Input, AC coupled on the host board (<i>Not Required</i>)	
25	PECL-I	RefCLK-	Reference Clock Inverted Input, AC coupled on the host board (<i>Not Required</i>)	
26		GND	Module Ground	1
27		GND	Module Ground	1
28	CML-I	TD-	Transmitter Inverted Data Input	
29	CML-I	TD+	Transmitter Non-Inverted Data Input	
30		GND	Module Ground	1

Note1: Module ground pins GND are isolated from the module case and chassis ground within the module.

Note2: Shall be pulled up with 4.7K-10Kohms to a voltage between 3.15V and 3.45V on the host board.

Digital Diagnostic Functions

As defined by the XFP MSA, digital diagnostic functions are provided via a 2-wire serial interface, which allows real-time access to the following operating parameters:

- Transceiver Temperature
- Tx Bias Current
- Tx Optical Power
- RX Received Optical Power
- Transceiver +3.3V Supply Voltage

Typical Application Circuit For Power Supply

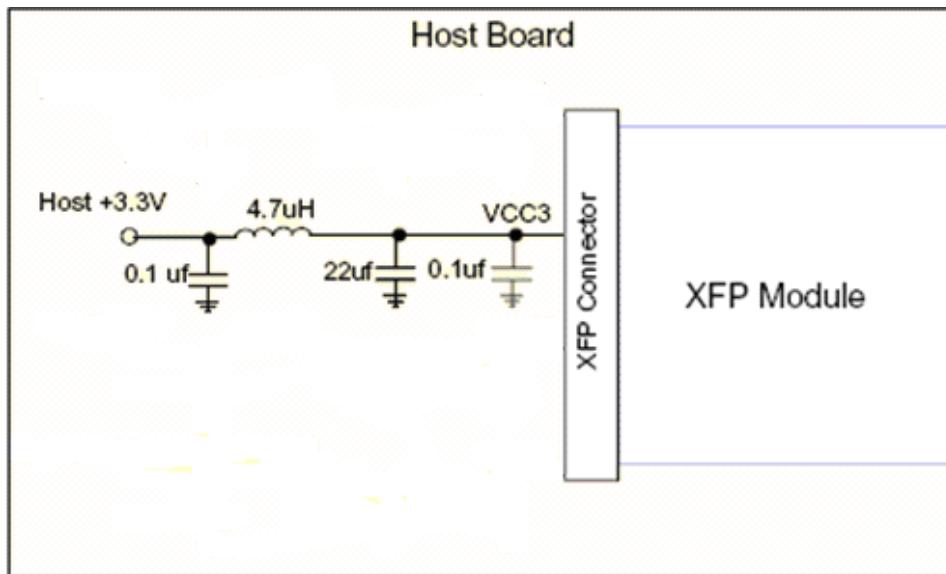

Figure 5 Example of Host Board Supply Filtering Network

Package Outline

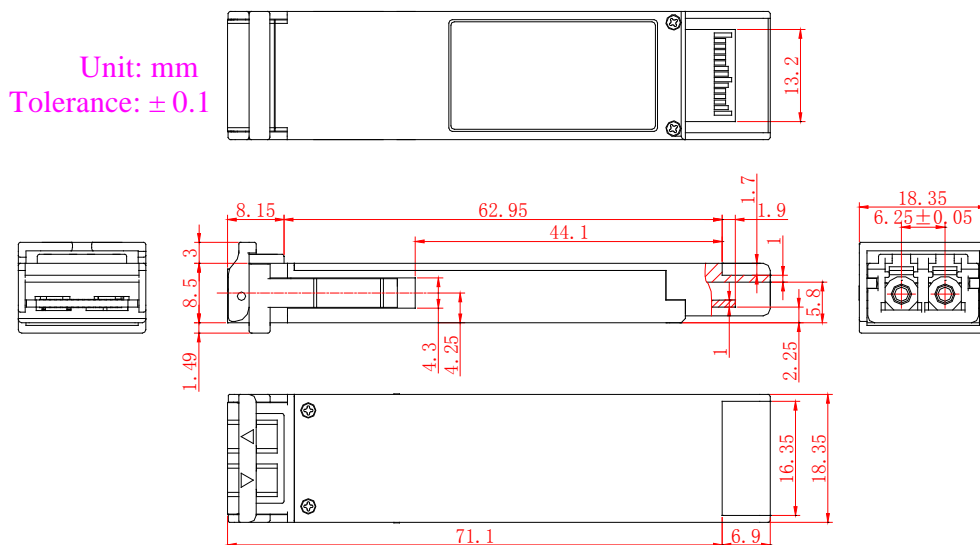

Figure 6 Package Outline
Wuhan Telecommunication Devices Co., Ltd.
<http://www.wtd.com.cn>

Regulatory Compliance

Table 7 Regulatory Compliance

Feature	Test Method	Performance
Laser Eye Safety	FDA 21 CFR 1040.10 and 1040.11 IEC 60825-1: 1994+ A11: 1996+ A2: 2001 IEC 60825-2: 2004 + A1: 2006 EN 60825-1:1994+A1:2002+A2:2001 EN 60825-2: 2004	Compliant with Class 1 laser product
Electrostatic Discharge (ESD) to the Electrical Pins	MIL-STD-883E Method 3015.7 Human Body Model	Class 1 (>1.5kV)
Electrostatic Discharge (ESD) Immunity	IEC 61000-4-2: 2001	Class 2 (>4.0kV)
Electromagnetic Interference (EMI)	FCC Part 15 Subpart J Class B CISPR22:1997+A1:2000+A2:2002, Class B EN55022:1998+A1:2000+A2:2003, Class B	Compliant with standards

Ordering Information

Part No.	Specifications								Application	
	Package	Data rate	Laser	Optical Power	Detector	Sensitivity	Temp	Reach		Other
RTXM226-408	XFP	9.95G~11.3G	1310nm DFB	-6 ~-1dBm	PIN	< -14dBm	0~70°C	10km	DDM	SDH I-64.1, 10GBASE-LR/LW

WTD reserves the right to make changes to the product(s) or information contained herein without notice. No liability is assumed as a result of their use or application. No rights under any patent accompany the sale of any such product(s) or information.

Edition 2009-12-01

Published by Wuhan Telecommunication Devices Co.,Ltd.

Copyright © WTD

All Rights Reserved.