



10Gb/s 300Pin MSA Transponders – Small Form Factor

RTXM225C-021

Features

- *Small Form Factor Package*
- *Microprocessor controls to support I2C*
- *Optical Rate from 9.953 Gb/s to 10.709 Gb/s*
- *Full Performance with operating case temperature from 0 to +65°C*
- *Power Supplies:*
 - *+5.0V, -5.2V, +3.3V*
- *Typical Power Dissipation 5W*
- *SFF for Easy Application on Line Cards*
- *MSA Compliant for Interoperability*
- *Multi-Rate for OC192/STM64, and FEC Rate Applicability*

Application

- *Subscriber Loop*
- *Metropolitan area networks*
- *Optical add-/drop-multiplexing*

Standard

- *300 Pin MSA Compliant*
- *OIF-SF14-01.0 compliant SERDES's I/O timing*
- *I2C Reference Document for 300PIN 10G and 40G Transponder (Edition 4). Compatible*

Absolute Maximum Ratings

Parameter	Symbol	Unit	Min	Max
Storage Temperature Range	T_s	°C	-40	85
Relative Humidity	RH	%		85
Voltage on LVDS pin		V	0	Vdd2
Static Discharge Voltage	ESD	V		500
Supply Voltages	Vcc	V	-0.5	6.0
	Vdd2	V	-0.5	3.6
	Vee	V	-5.6	0.5

Recommended Operating Conditions

Parameter	Symbol	Unit	Min	Typ	Max
Case Operating Temperature Range	T_c	°C	0		65
Power Supply Voltage	V _{CC}	V	4.75	5.0	5.25
	V _{DD2}	V	3.13	3.3	3.47
	V _{EE}	V	-4.94	-5.2	-5.45

Specifications

Minimum and maximum parameters are specified End-of-Life within the overall relevant operating temperature range unless otherwise stated.

Typical values are referenced to +25 °C, nominal power supply, beginning of life.









Parameter	Symbol	Unit	Min	Typ	Max	Test condition
Electrical Characteristics						
-5.2V Supply Current	I_{EE}	mA		400	500	
+3.3V Supply Current	I_{DD2}	mA		700	1500	

+5.0V Supply Current	I _{cc}	mA	100	200
Power Dissipation		W	5	9
Optical transmitter Characteristics				
Data rate		Gbps	9.953	
Average Output Power	P _o	dBm	+3	+6
Center Wavelength range	λ	nm	1530	1565
Extinction ratio	EX	dB	9	10
Dispersion Penalty		dB		2
BER=10 ⁻¹² ,2 ³¹ -1PRBS 1600ps/nm 9.953Gb/s				
Spectral width(-20dBm)		nm		0.3
BOL				
SMSR		dB	35	
Eye diagram	Compliant with ITU-TG.691 STM-64 Eye diagram Mask or IEEE802.3ae Eye diagram Mask			
Optical receive Characteristics				
Data rate		Mbps	9.953	10.709
Receiver Sensitivity	S	dBm	-25	-24
Receiver Overload		dBm	-9	
BER=10 ⁻¹² ,2 ³¹ -1PRBS 9.953Gb/s				
Jitter Performance	Compliant with ITU-T G.783, G.825			
Loss of Power		dBm		-37
Optical return loss		dB	-27	

Pin Description

	K	J	H	G	F	E	D	C	B	A
1	+5.0V	NC	GND	RxDout12P	+1.8V	RxDout8P	GND	RxDout4P	GND	RxDout0P
2	+5.0V	FFU	GND	RxDout12N	+1.8V	RxDout8N	GND	RxDout4N	GND	RxDout0N
3	NC	NC	NC	GND	RxPOWMON	GND	I2CAD0	GND	NC	GND
4	+3.3V	NC	GND	RxDout13P	+3.3V	RxDout9P	GND	RxDout5P	GND	RxDout1P
5	+3.3V	NC	GND	RxDout13N	+3.3V	RxDout9N	GND	RxDout5N	GND	RxDout1N
6	NC	NC	NC	GND	RxPOWALM	GND	I2CAD1	GND	RxMUTEDOUT	GND
7	+3.3V	FFU	GND	RxDout14P	+3.3V	RxDout10P	GND	RxDout6P	GND	RxDout2P
8	+3.3V	FFU	GND	RxDout14N	+3.3V	RxDout10N	GND	RxDout6N	GND	RxDout2N
9	RxMUTEPOCLK	NC	FFU	GND	NC	GND	I2CAD2	GND	RxLCKREF	GND
10	-5.2V	NC	GND	RxDout15P	-5.2V	RxDout11P	GND	RxDout7P	GND	RxDout3P
11	-5.2V	NC	GND	RxDout15N	-5.2V	RxDout11N	GND	RxDout7N	GND	RxDout3N
12	RxMUTEMCLK	FFU	FFU	GND	NC	GND	MOD_RESET	GND	RxMCLKSEL	GND
13	-5.2V	FFU	GND	NC	-5.2V	RxPOCLKP	GND	RxMCLKP	GND	RxREFCLKP
14	-5.2V	NC	GND	NC	-5.2V	RxPOCLKN	GND	RxMCLKN	GND	RxREFCLKN
15	I2CCLOCK	NC	ALM-INT ¹	GND	RxREFSEL	GND	FFU	GND	RxLOCKERR	GND
16	+5.0V	NC	GND	TxDin12P	+1.8V	TxDin8P	GND	TxDin4P	GND	TxDin0P
17	+5.0V	FFU	GND	TxDin12N	+1.8V	TxDin8N	GND	TxDin4N	GND	TxDin0N
18	I2CDATA	NC	NC	GND	LsBIASMON	GND	LsPOWMON	GND	NC	GND
19	+3.3V	NC	GND	TxDin13P	+3.3V	TxDin9P	GND	TxDin5P	GND	TxDin1P
20	+3.3V	NC	GND	TxDin13N	+3.3V	TxDin9N	GND	TxDin5N	GND	TxDin1N
21	NC	NC	NC	GND	LsENABLE	GND	LsTEMPMON	GND	NC	GND
22	+3.3V	FFU	GND	TxDin14P	+3.3V	TxDin10P	GND	TxDin6P	GND	TxDin2P

23	+3.3V	FFU	GND	TxDin14N	+3.3V	TxDin10N	GND	TxDin6N	GND	TxDin2N
24	TxRESET	NC	NC	GND	LsBIASALM	GND	TxPHSADJ0	GND	NC	GND
25	-5.2V	NC	GND	TxDin15P	-5.2V	TxDin11P	GND	TxDin7P	GND	TxDin3P
26	-5.2V	NC	GND	TxDin15N	-5.2V	TxDin11N	GND	TxDin7N	GND	TxDin3N
27	TxFIFORES	NC	NC	GND	TxTEMPALM	GND	TxPHSADJ1	GND	NC	GND
28	-5.2V	NC	GND	TxPICLKP	-5.2V	TxPCLKP	GND	TxMCKP	GND	TxREFCLKP
29	-5.2V	NC	GND	TxPICLKN	-5.2V	TxPCLKN	GND	TxMCKN	GND	TxREFCLKN
30	TxFIFOERR	NC	TxLINETIMSEL	GND	TxREFSEL	GND	LsPOWALM	GND	TxLOCKERR	GND

	Receiver power & GND supplies		Transmitter power & GND supplies		NC: no user connection
	Receiver d.c. signals		Transmitter d.c. signals		FFU: reserved for future use
	622 differential signals		622 differential signals		

NOTE1: for soft control mode version only

Block Diagram

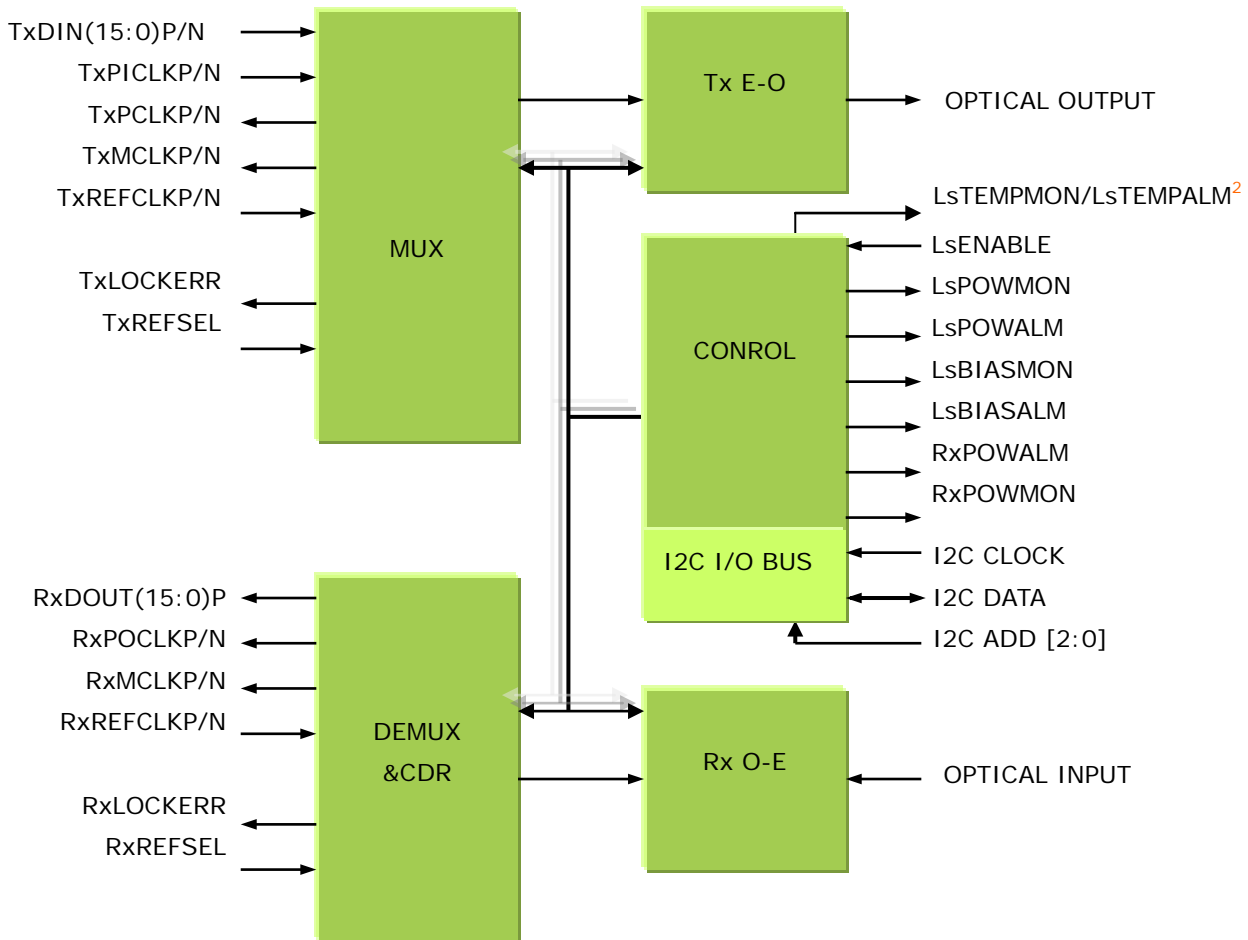

Note2: for Cooled Version only

Typical Application Circuit

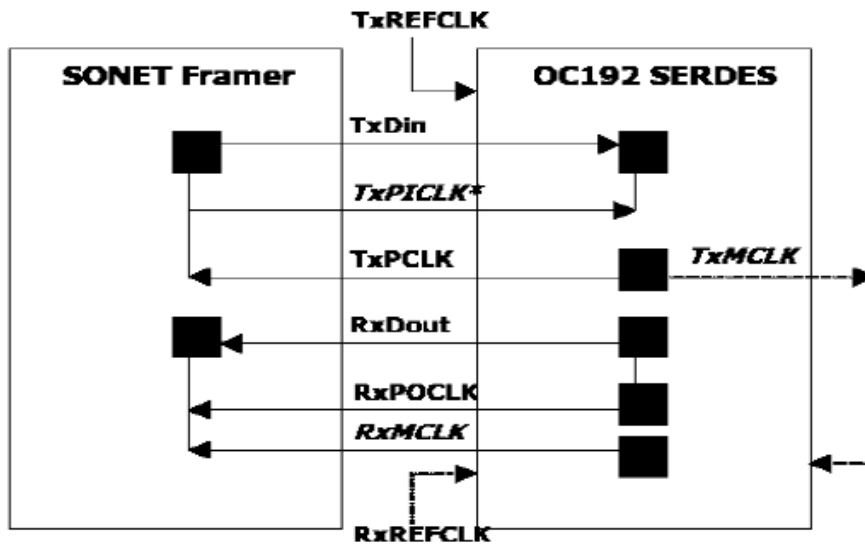

Package Outline (Unit: mm)

Package with Heat Sink

Unit: mm

Tolerance: ± 0.1 mm,

Unless otherwise specified

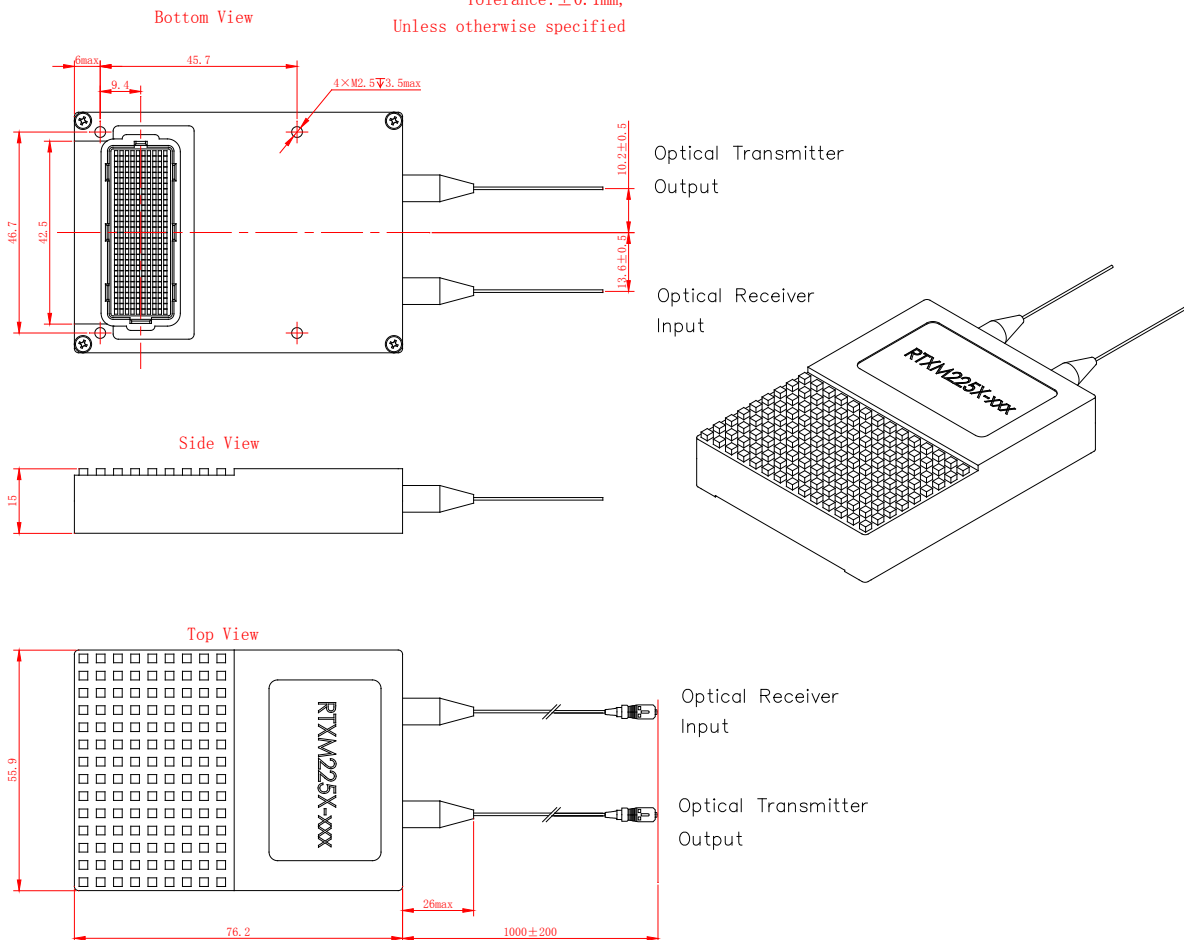

Ordering Information

Part No.	Specifications									Application	
	Pack	Rate	Tx	Pout	Rx	S	Top	Reach	others		
RTXM225C-021	SFF	10G	1550nm	EML	+3~+6dBm	APD	-25dBm	0~65°C	80km	Note1 LC/PC	L-64.2C2

Note1: Soft control mode

WTD reserves the right to make changes to the product(s) or information contained herein without notice. No liability is assumed as a result of their use or application. No rights under any patent accompany the sale of any such product(s) or information.

Edition 2010-2-9(V2)

Published by Wuhan Telecommunication Devices Co.,Ltd.

Copyright © WTD

All Rights Reserved.