



125Mb/s to 1.25Gb/s BIDI SFP transceiver modules

RTXM182 Series

Features

- *Single LC receptacle optical interface compliant*
- *Single +3.3V power supply*
- *Hot-pluggable*
- *Receiver Loss of Signal Output*
- *AC coupling of PECL signals*
- *Serial ID module on MOD(0-2)*
- *International Class 1 laser safety certified*
- *Transmitter disable input*
- *Operating temperature range: -5°C ~ +75°C*
- *RoHS Compliant*

Application

- *Gigabit Ethernet*
- *Gigabit Fiber Channel*
- *Switch to switch interface*
- *Switched backplane applications*

Standard

- Compliant with SFP MSA (INF-8074i)
- Compliant with IEEE802.3ah
- ITU-T G.957 S-1.1

Absolute Maximum Ratings

Parameter	Symbol	Unit	Min	Max
Storage Temperature Range	T_s	°C	-40	+85
Relative Humidity	RH	%	5	95
Power Supply Voltage	V_{cc}	V	-0.5	+4

Recommended Operating Conditions

Parameter	Symbol	Unit	Min	Typ	Max
Operating Case Temperature Range	T_c	°C	-5		75
Power Supply Voltage	V_{cc}	V	3.135	3.3	3.465
Data rate		Mb/s	-	155/1250	-

Specifications

(tested under recommended operating conditions, unless otherwise noted)

Parameter	Symbol	Unit	Min	Typ	Max	Notes	
Electrical Characteristics							
Supply Current	Tx Section	I_{cc}	mA	-	-	300	1
	Rx Section						
Single Ended Data Input Swing		mV	150	-	1100		
Single Ended Data Output Swing		mV	300	-	600		
TX_fault /LOS output(TTL)	VOH	V	2.0	-	V_{cc}		
	VOL		0	-	0.8		
TX_disable input(TTL)	VOH	V	2.0	-	V_{cc}		
	VOL		0	-	0.8		

1.25G BIDI SFP

Optical transmitter Characteristics						
Launch Optical Power	P_o	dBm	-9	-5	-3	
Center Wavelength Range	λ_c	nm	1278	1310	1351	FP-LD
			1480	1490	1500	DFB-LD
Extinction Ratio	EX	dB	9			
Spectral Width	$\Delta\lambda$	nm			3.5	FP-LD

			0.88 DFB-LD		
Total transmitter Jitter	Tp-p	ps	267 2		
Relative Intensity Noise	RIN	dB/H _z	-113		
Eye Diagram	Compliant with IEEE802.3ah				
Dispersion Penalty			dB 1		
Optical Rise/Fall Time	Trise/Tfall	ps	260 3		
Pout of OFF transmitter	P _{off}	dBm	-	-	-45
Optical receiver Characteristics					
Center Wavelength Range	λ_c	nm	1260	1360	
			1480	1500	
Receiver Sensitivity	S	dBm	-22		
Overload Input Optical Power	P _{in}	dBm	0		
LOS	Optical Dessert		dB -23		
	Optical Assert		-35		
LOS Hysteresis			dB 0.5	3	5

155M BIDI SFP

Optical transmitter Characteristics					
Launch Optical Power	P _o	dBm	-14	-	-8
Center Wavelength Range	λ_c	nm	1260	1310	1360 FP-LD
			1480	1550	1580 FP-LD
Extinction Ratio	EX	dB	10		
Spectral Width	$\Delta\lambda$	nm	6 1310nm FP-LD		
			3 1550nm FP-LD		
Total transmitter Jitter	Tp-p	ns	1 2		
Relative Intensity Noise	RIN	dB/H _z	-116		
Eye Diagram	Compliant with IEEE802.3ah				
Dispersion Penalty			dB 1		
Optical Rise/Fall Time	Trise/Tfall	ns	1.5 3		
Pout of OFF transmitter	P _{off}	dBm	-	-	-45
Optical receiver Characteristics					
Center Wavelength Range	λ_c	nm	1260	1360	
			1480	1600	
Receiver Sensitivity	S	dBm	-31		
Overload Input Optical Power	P _{in}	dBm	-3		
LOS	Optical Dessert		dB -32		
	Optical Assert		-43		
LOS Hysteresis			dB 0.5	3	5

Note 1: The supply current includes SFP module's supply current and test board working current.

Note 2: TP refers to the compliance point specified in IEEE802.3ah.

Note 3: Optical transition time is the time interval required for the rising or falling edge of an optical pulse to transition between the 20% and 80% amplitudes relative to the logical 1 and 0 levels

Memory Map

2 wire address 1010000X (A0)

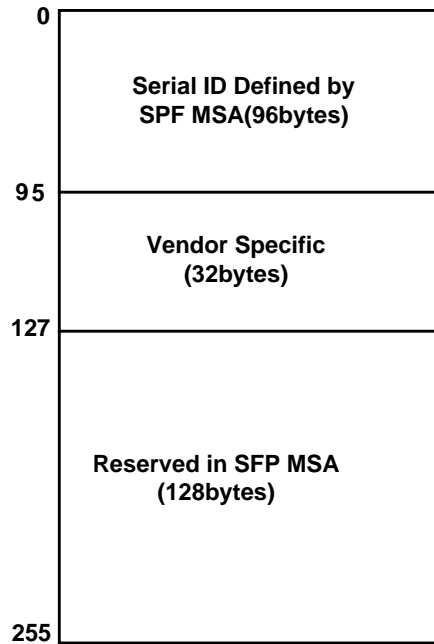

EEPROM Serial ID Memory Contents

Accessing Serial ID Memory uses the 2 wire address 1010000X (A0). Memory Contents of Serial ID are shown in Table 2.

Table 2 Serial ID Memory Contents

Data Address (Bytes)	Size	Name of Field	Contents(Hex)	Description
BASE ID FIELDS				
0	1	Identifier	03	SFP
1	1	Ext. Identifier	04	SFP function is defined by serial ID only
2	1	Connector	07	LC Connector
3-10	8	Transceiver		Transceiver Codes
11	1	Encoding	03	NRZ
12	1	BR, Nominal		Data rate
13	1	Reserved	00	
14	1	Length (9µm) km	0F	Transceiver transmit distance 15km
15	1	Length (9µm) 100m		
16	1	Length (50µm) 10m		

17	1	Length(62.5µm)10m		
18	1	Length (Copper)	00	Not compliant
19	1	Reserved	00	
20-35	16	Vendor name	57 54 44 20 20 20 20 20 20 20 20 20 20 20	"WTD"(ASCII)
36	1	Reserved	00	
37-39	3	Vendor OUI	00 1C AD	
40-55	16	Vendor PN		Transceiver part number
56-59	4	Vendor rev	20 20 20 20	
60-61	2	Wavelength		Transceiver wavelength
62	1	Reserved	00	
63	1	CC_BASE	Check Sum (Variable)	Check code for Base ID Fields
EXTENDED ID FIELDS				
64-65	2	Options	00 1A	TX_DISABLE, TX_FAULT and Loss of Signal implemented.
66	1	BR,max	00	
67	1	BR,min	00	
68-83	16	Vendor SN	42 30 30 39 38 32 32 20 20 20 20 20 20 20 20	Serial Number of transceiver (ASCII). For example "B009822".
84-91	8	Date code	30 32 31 30 30 35 20 20	Manufactory date code. For example "021005".
92-94	3	Reserved	00 00 00	
95	1	CC_EXT	Check Sum (Variable)	Check sum for Extended ID Field.
VENDOR SPECIFIC ID FIELDS				
96-127	32	Vendor Specific	Read only	Depends on customer information
128-255	128	Reserved	Read only	Filled by zero

Pin Description

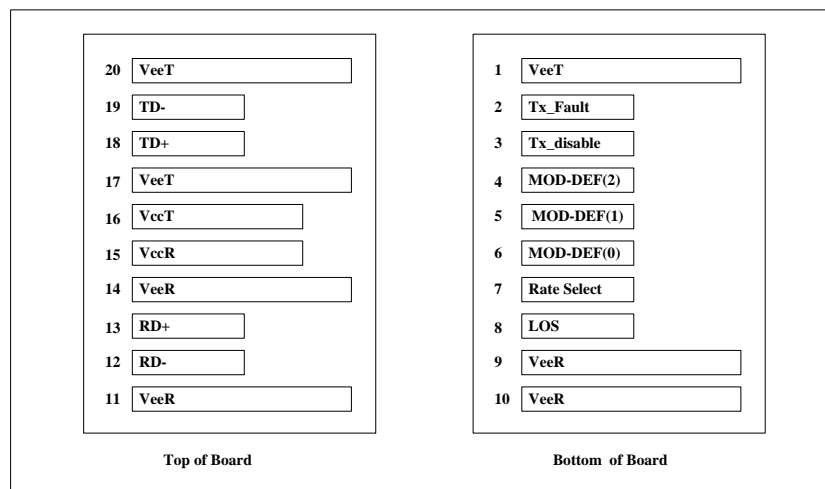

As Viewed Through Top of Board

Pin	Name	Function/Description	Engagement order	Notes
1	VeeT	Transmitter Ground	1	
2	TX Fault	Transmitter Fault Indication	3	1
3	TX Disable	Transmitter Disable-Module disables on high or open	3	2
4	MOD-DEF2	Module Definition 2-Two wire serial ID interface	3	3
5	MOD-DEF1	Module Definition 1-Two wire serial ID interface	3	3
6	MOD-DEF0	Module Definition 0-Two wire serial ID interface	3	3
7	Rate Select	Not Connected	3	
8	LOS	Loss of Signal	3	4
9	VeeR	Receiver Ground	1	
10	VeeR	Receiver Ground	1	
11	Veer	Receiver Ground	1	
12	RD-	Inverse Received Data out	3	5
13	RD+	Received Data out	3	5
14	VeeR	Receiver Ground	1	
15	VccR	Receiver Power ---- +3.3V±5%	2	6
16	VccT	Transmitter Power ---- +3.3 V±5%	2	6
17	VeeT	Transmitter Ground	1	
18	TD+	Transmitter Data In	3	7
19	TD-	Inverse Transmitter Data In	3	7
20	VeeT	Transmitter Ground	1	

Note 1: TX Fault is open collector/drain output which should be pulled up externally with a 4.7K – 10KΩ resistor on the host board to supply $V_{ccT}+0.3V$ or $V_{ccR}+0.3V$. When high, this output indicates a laser fault of some kind. Low indicates normal operation. In the low state, the output will be pulled to <math><0.8V</math>.

Note 2: TX Disable input is used to shut down the laser output per the state table below. It is pulled up within the module with a 4.7 – 10K resistor.

Low (0 – 0.8V): Transmitter on
 Between (0.8V and 2V): Undefined
 High (2.0 – V_{ccT}): Transmitter Disabled
 Open : Transmitter Disabled

Note 3: Mod-Def 0, 1, 2. These are the module definition pins. They should be pulled up with a 4.7 - 10K resistor on the host board to supply less than $V_{ccT}+0.3V$ or $V_{ccR}+0.3V$.

Mod-Def 0 is grounded by the module to indicate that the module is present.

Mod-Def 1 is clock line of two wire serial interface for optional serial ID.

Mod-Def 2 is data line of two wire serial interface for optional serial ID.

Note 4: LOS (Loss of signal) is an open collector/drain output which should be pulled up externally with a 4.7 – 10K resistor on the host board to supply $V_{ccT}+0.3V$ or $V_{ccR}+0.3V$. When high, this output indicates the received optical power is below the worst case receiver sensitivity (as defined by the standard in use). Low indicates normal operation. In the low state, the output will be pulled to <math><0.8V</math>.

Note 5: RD-/+: These are the differential receiver outputs. They are AC coupled 100Ω differential lines which should be terminated with 100Ω differential at the user SERDES. The AC coupling is done inside the module

and thus not required on the host board.

Note 6: VccR and VccT are the receiver and transmitter power supplies. They are defined as $3.3V \pm 5\%$ at the SFP connector pin. The in-rush current will typically be no more than 30mA above steady state supply current after 500ns.

Note 7: TD-/+: These are the differential transmitter inputs. They are AC coupled differential lines with 100Ω differential termination inside the module. The AC coupling is done inside the module and is thus not required on host board.

Block diagram

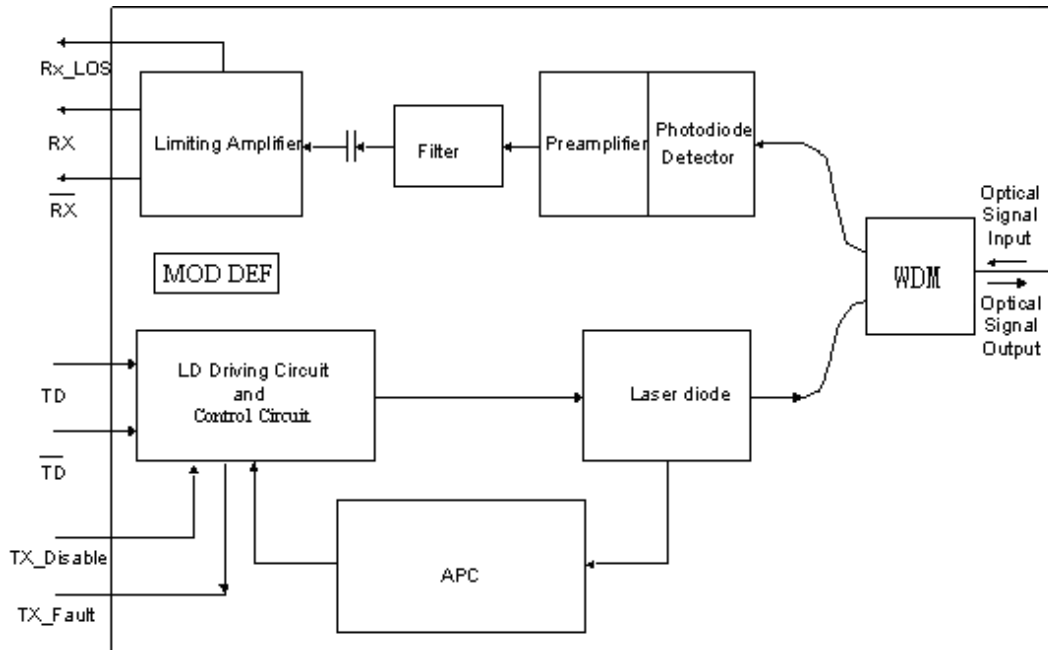

Required Host Board Components

The MSA power supply noise rejection filter is required on the host PCB to meet data sheet performance. The MSA filter incorporates an inductor which should be rated 400mADC and 1Ω serial resistance or better. It should not be replaced with a ferrite. The required filter is illustrated in Figure 3. The MSA also specifies that $4.7K$ to $10K\Omega$ pull-up resistors for TX_FAULT, LOS, and MOD_DEF0,1,2 are required on the host PCB. Figure is the suggested transceiver/host interface.

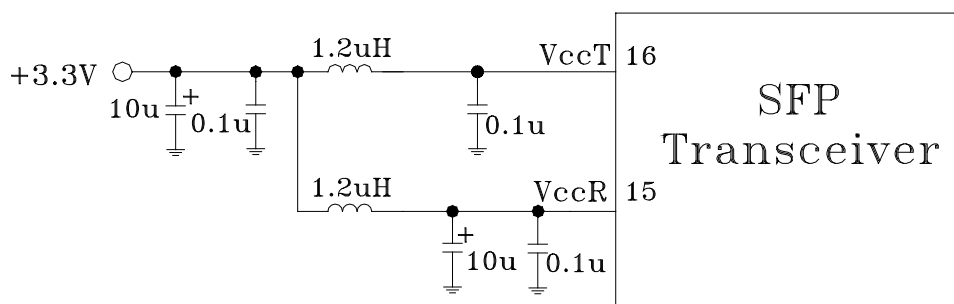

Typical application circuit

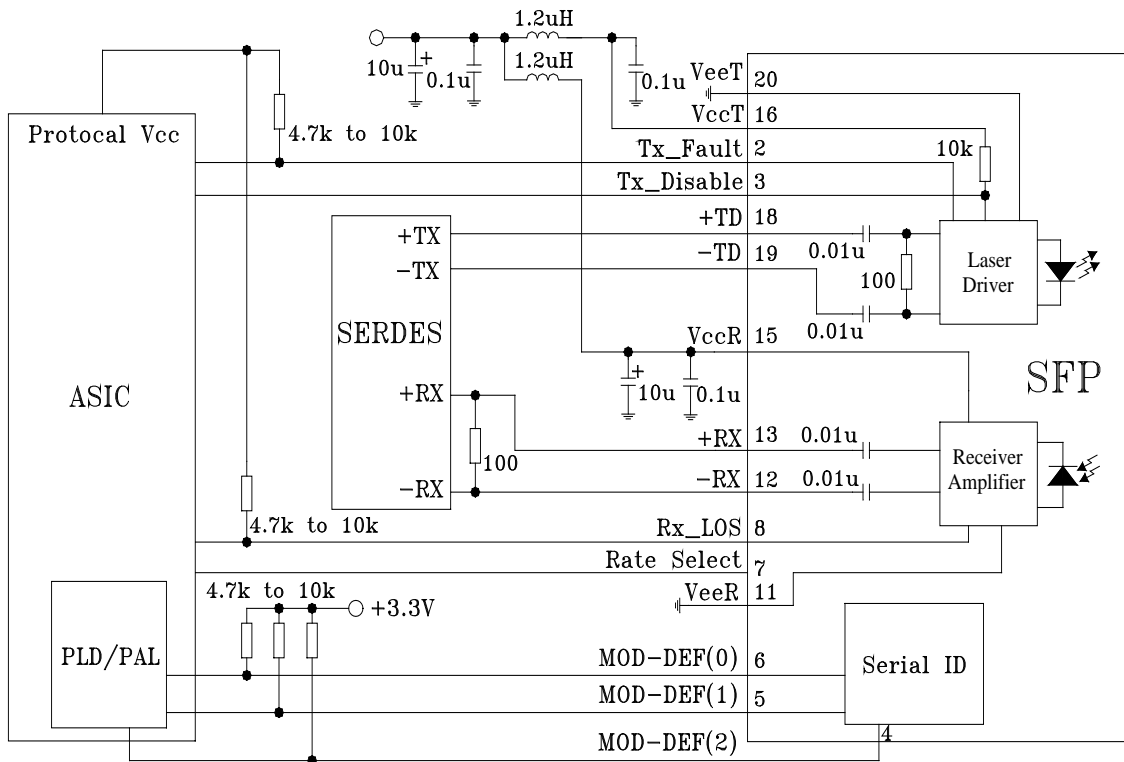

Package outline

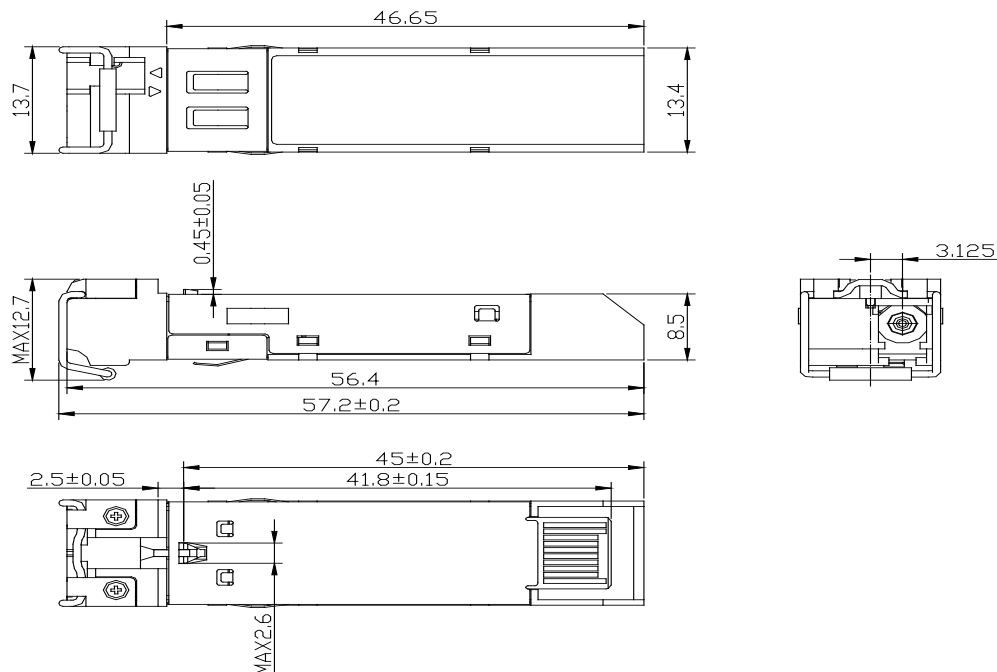

Unit: mm
Unspecified Tolerance: ±0.1mm

PCB layout recommendation

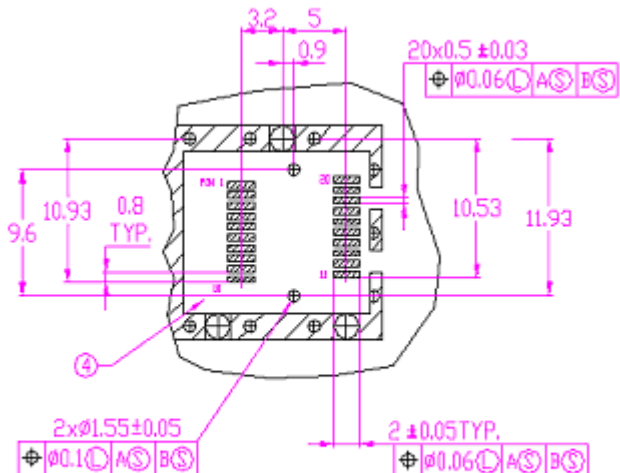
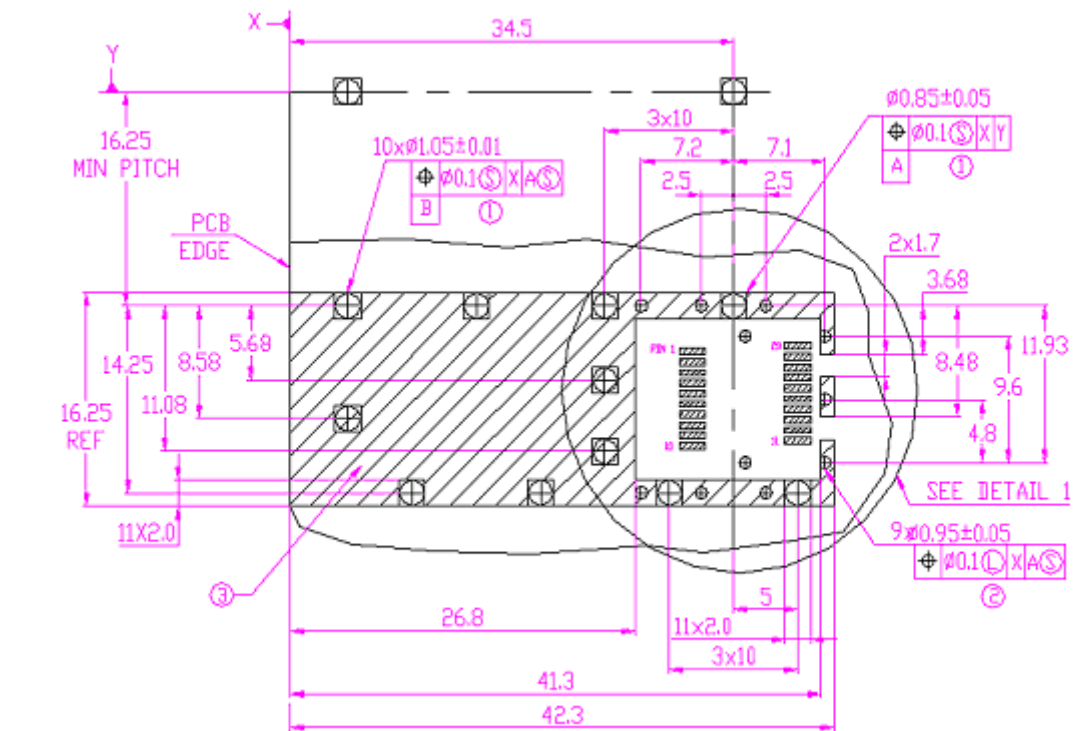

DETAIL 1

- NOTES:
- 1.PADS AND VIAS ARE CHASSIS GROUND.
 - 2.THROUGH HOLES,PLATING OPTIONAL.
 - 3.HATCHED AREA DENOTES COMPONENT AND TRACE KEEPOUT (EXCEPT CHASSIS GROUND).
 - 4.AREA DENOTES COMPONENT KEEPOUT (TRACES ALLOWED).
- DIMENSIONS IN MILLIMETERS

Regulatory Compliance

Feature	Test Method	Performance
Electrostatic Discharge (ESD) to the Electrical Pins	MIL-STD-883E Method 3015.7	Class 1 (>1.5kV) – Human Body Model
Electrostatic Discharge (ESD) Immunity	IEC61000-4-2	Class 2(>4.0kV)
Electromagnetic Interference (EMI)	CISPR22 ITE Class B FCC Class B CENELEC EN55022 VCCI Class 1	Compliant with standard
Immunity	IEC61000-4-3 Class 2	Typically show no measurable effect from a 3 V/m field swept from 80 to 1000MHz applied to the transceiver without a chassis enclosure.
Safety	FDA CDRH 21-CFR 1040 Class 1	
	UL	
	TUV-GS	
	CE	

Ordering Information

Part No.	Specifications										Application
	Pack	Data rate	Tx	Pout	Rx	S	Top	Reach	Others	Code	
RTXM182-401	SFP	155M	1310nm FP-LD	-14 ~ -8dBm	PIN 1550nm < -31dBm	-5~75°C	15km	RoHS	100Base-BX10		
RTXM182-402	SFP	155M	1550nm FP-LD	-14 ~ -8dBm	PIN 1310nm < -31dBm	-5~75°C	15km	RoHS	100Base-BX10		
RTXM182-421	SFP	1.25G	1310nm FP-LD	-9 ~ -3dBm	PIN 1490nm < -22dBm	-5~75°C	15km	RoHS	1000Base-BX10		
RTXM182-422	SFP	1.25G	1490nm DFB-LD	-9 ~ -3dBm	PIN 1310nm < -22dBm	-5~75°C	15km	RoHS	1000Base-BX10		

WTD reserves the right to make changes to the product(s) or information contained herein without notice. No liability is assumed as a result of their use or application. No rights under any patent accompany the sale of any such product(s) or information.

Edition 2009-12-1

Published by Wuhan Telecommunication Devices Co.,Ltd.

Copyright © WTD

All Rights Reserved.