



3.3V SFF 2×10 1.25G CWDM Transceiver Module

RTXM177XC Series

Features

- *Duplex LC receptacle optical interface*
- *SFF 2×10 metallic package with EMI nose shield*
- *Distance up to 40 km on 9/125 μm SMF cables*
- *C+L band and 20nm span*
- *CML or PECL Logic I/O Interfaces*
- *TTL transmitter disable input*
- *Receiver signal detect output (TTL / PECL optional)*
- *Single + 3.3V power supply*
- *Low power consumption*

Application

- *CWDM optic fiber transmission system*
- *Gigabit Ethernet*

Standard

- Compliant with SFF MSA July 5,2000
- Compliant with IEEE 802.3z
- Compliant with ITU-T G.695

Absolute Maximum Ratings

Parameter	Symbol	Unit	Min	Max
Storage Temperature	T _s	°C	- 40	+ 85
Relative Humidity	RH	%	5	95
Power Supply Voltage	V _{cc}	V	- 0.5	+ 4.0
Lead Solder Temperature		°C	-	260
Lead Solder Duration		sec	-	10

Note: Stresses in excess of absolute maximum ratings may cause damage to the device. Exposure to absolute maximum ratings for extended periods may affect device reliability.

Recommended Operating Conditions

Parameter	Symbol	Unit	Min	Typ	Max
Ambient Operating Temperature	T _A	°C	0	-	+ 70
Power Supply Voltage	V _{cc}	V	3.14	3.3	3.47

Specifications (tested under recommended operating conditions, unless otherwise noted)

Parameter	Symbol	Unit	Min	Typ	Max	Note
Electrical Characteristics						
Supply Current	I _{cc}	mA	-	-	250	
Transmitter Differential Data Input Swing	V _{IN}	mV	400	-	2000	1
Transmitter Disable Voltage	V		V _{cc} -1.3	-	V _{cc} +0.3	
Transmitter Enable Voltage	V		0	-	0.8	
Transmitter Disable Assert Time	t _{off}	μs	-	-	10	
Transmitter Disable Deassert Time	t _{on}	ms	-	-	1.0	
Receiver Differential Data Output Swing	V _{OUT}	mV	370	-	2000	2
Singnal Detect	High	-	V	V _{cc} -1.3	-	V _{cc} +0.3
Output Voltage (TTL)	Low	-	V	0	-	0.8
Singnal Detect	High	-	V	V _{cc} -1.1	-	V _{cc} -0.7
Output Voltage (PECL)	Low	-	V	V _{cc} -1.95	-	V _{cc} -1.5
Optical Transmitter Characteristics						
Launch Optical Power	P ₀	dBm	- 5	-	0	3, 4
Center Wavelength Range	λ _c	nm	λ _c -6.5	λ _c	λ _c +6.5	
Extinction Ratio	E _x	dB	9	-	-	

Spectral Width (- 20dB)	$\Delta\lambda$	nm	-	-	1
Rise/Fall Time (20% ~ 80%)	tr/tf	ns	-	-	0.26
Disabled Transmitter Output Power	-	dBm	-	-	- 35
Eye Diagram	IEEE 802.3z				5
Optical Receiver Characteristics					
Receiver Sensitivity	S	dBm	-	-	- 22 6
Overload Input Optical Power	-	dBm	- 3	-	-
Signal Detect	Assert	-	dBm	-	- 22
	De-assert	-	dBm	- 35	-
Signal Detect Hysteresis	-	dB	0.5	-	-

Note 1: AC coupled internally.

Note 2: AC or DC (optional) coupled internally.

Note 3: Minimum output optical level is at end of life (EOL).

Note 4: Coupled into 9/125 μ m SMF.

Note 5: Measured with PRBS 2⁷-1 test pattern @1.25Gbps.

Note 6: Measured with PRBS 2⁷-1 test pattern @1.25Gbps, $E_x=10$ dB, $BER \leq 10^{-12}$.

Pin Description

Pin Name	Description	Pin Name	Description
1	Vpd Photodetector bias current, connected to VCCR through a resistor externally	11	V _{CCT} Transmitter Power Supply
2	V _{EER} Receiver Signal Ground	12	V _{EET} Transmitter Signal Ground
3	V _{EER} Receiver Signal Ground	13	TXdis Transmitter Disable Normal Operation: logic "0" or Open Circuit --Laser on Transmit Disabled: logic "1" --Laser off
4	NC Do not connect	14	TD+ Transmitter Data In
5	NC Do not connect	15	TD- Transmitter Data In Bar
6	V _{EER} Receiver Signal Ground	16	V _{EET} Transmitter Signal Ground
7	V _{CCT} Receiver Power Supply	17	Bmon- LD bias current monitor-negative end
8	SD Signal Detect Normal Operation: logic "1" output Fault Condition: logic "0" output	18	Bmon+ LD bias current monitor-positive end
9	RD- Received Data Output Bar	19	Pmon- LD optical power monitor-negative end
10	RD+ Received Data Output	20	Pmon+ LD optical power monitor-

Block Diagram

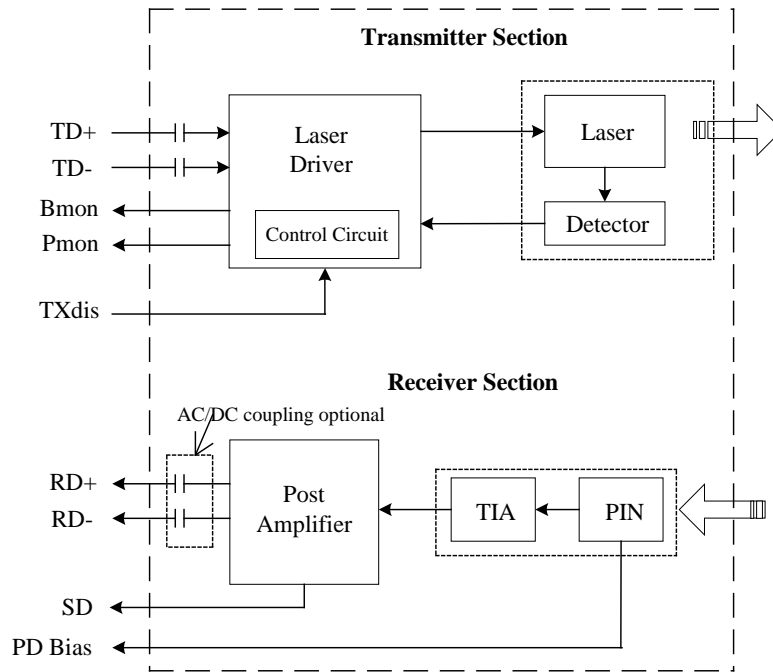

Typical Application Circuit

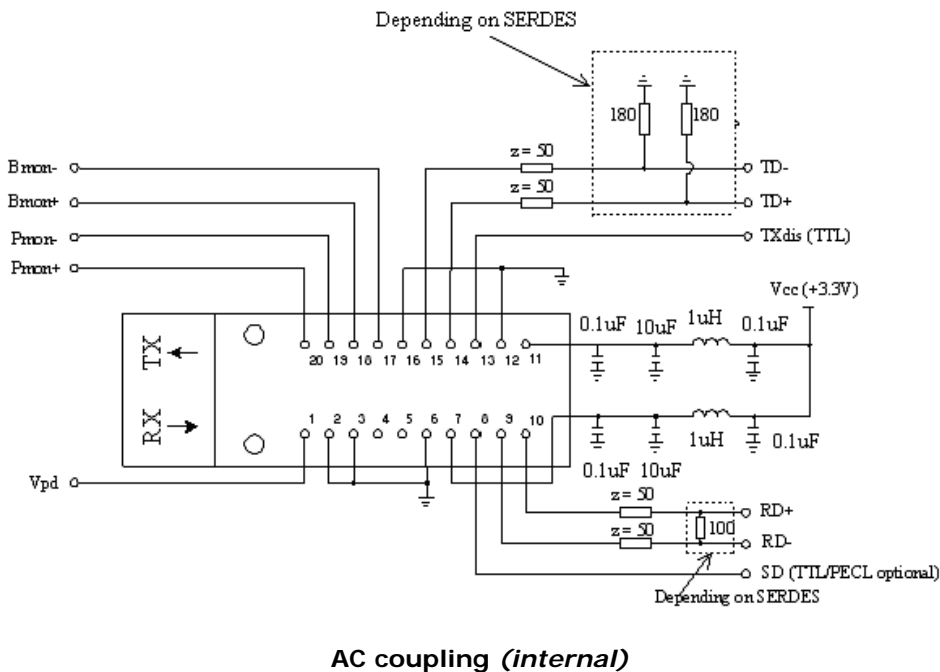

AC coupling (internal)

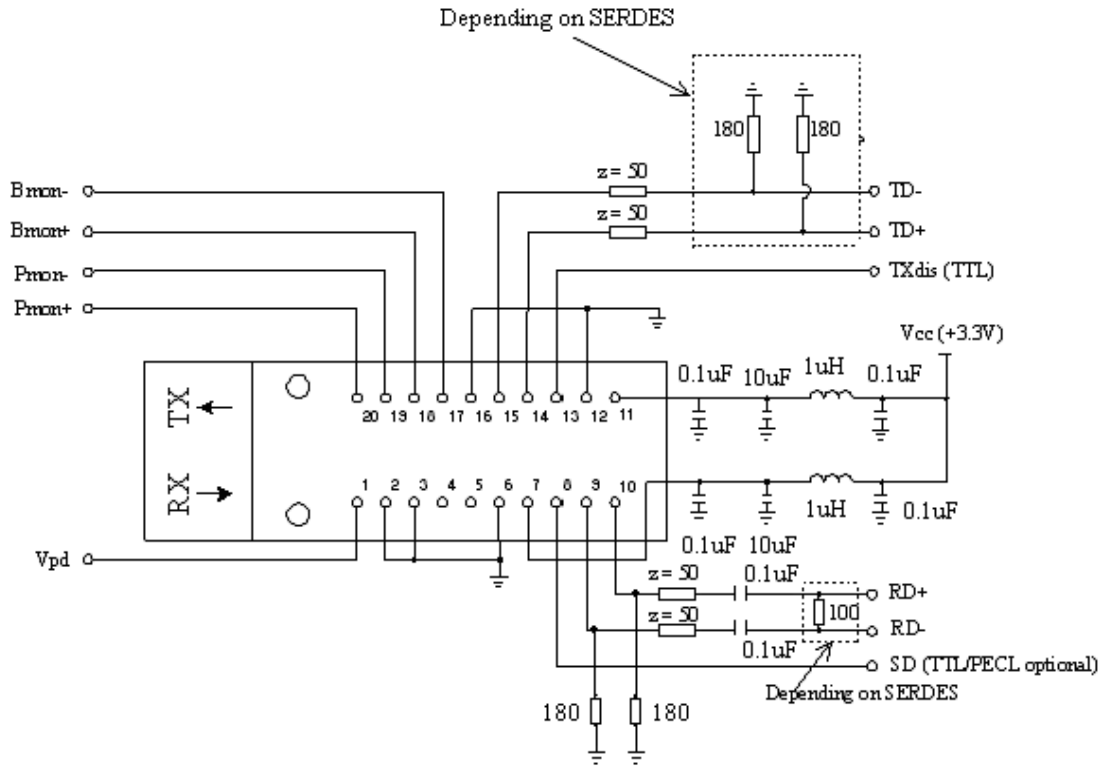

DC coupling (internal)

Package Outline (units in mm)

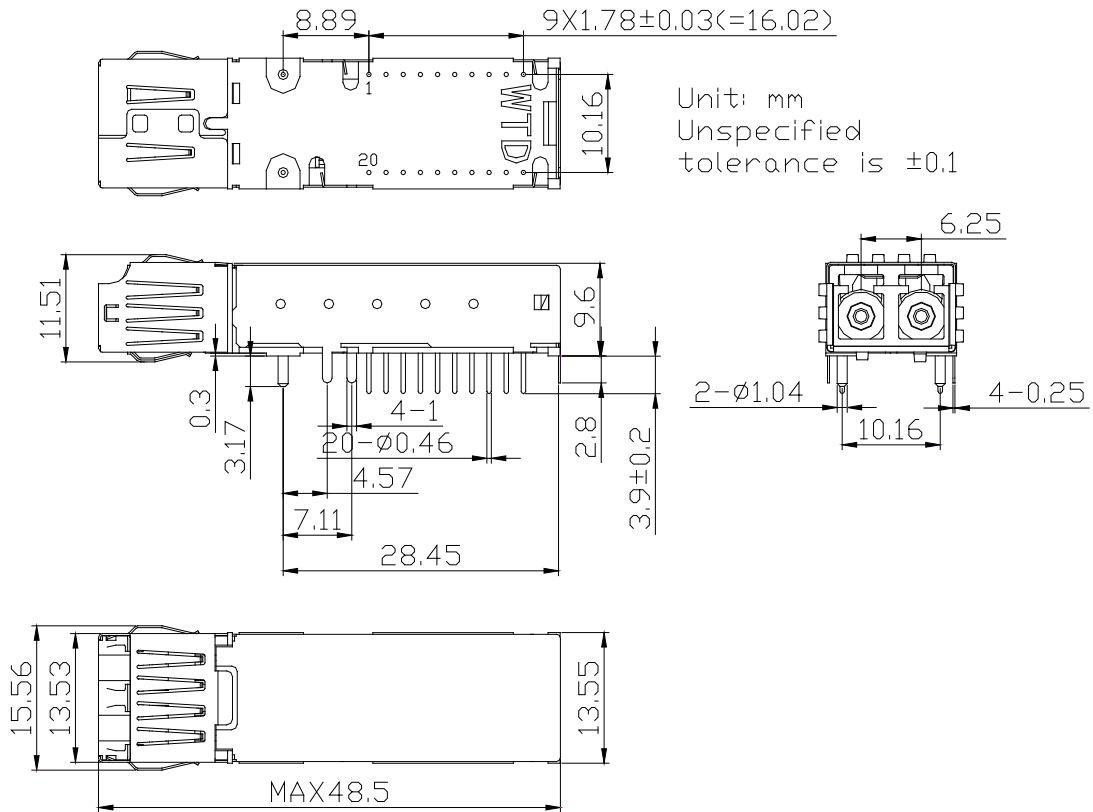

Regulatory Compliance

Feature	Test Method	Performance
Electrostatic Discharge (ESD) to the Electrical Pins	MIL-STD-883E Method 3015.7	Class 1 (>1.5kV) – Human Body Model
Electrostatic Discharge (ESD) Immunity	IEC61000-4-2	Class 2(>4.0kV)
Electromagnetic Interference (EMI)	CISPR22 ITE Class B EN55022 Class B	Compliant with standards
Immunity	IEC61000-4-3 Class 2 EN55024	Typically show no measurable effect from a 3V/m field swept from 80 to 1000MHz applied to the transceiver without a chassis enclosure.
Eye Safety	FDA 21 CFR 1040.10 and 1040.11 UL TUV EN 60825-1	Compliant with Class I, CDRH/IEC 825 UL file E239070

Update Information

From datasheet V3.0 to datasheet V3.1

1. Correct the parameter "Dessert" from "-30dBm" to "-35dBm" (in "specifications" table page 2).

Ordering Information

Part No.	Specifications										Application
	Package	Data rate	Laser	Optical Power	Detector	Sensitivity	Signal Coupling	SD Level	Temp	Reach	
RTXM177XC-A1*	2x10 SFF	1.25G	1471nm DFB	-5 ~ 0 dBm	PIN	- 22dBm (max)	AC	TTL	0~70°C	40km	CWDM
RTXM177XC-A2*	2x10 SFF	1.25G	1491nm DFB	-5 ~ 0 dBm	PIN	- 22dBm (max)	AC	TTL	0~70°C	40km	CWDM
RTXM177XC-A3*	2x10 SFF	1.25G	1511nm DFB	-5 ~ 0 dBm	PIN	- 22dBm (max)	AC	TTL	0~70°C	40km	CWDM
RTXM177XC-A4*	2x10 SFF	1.25G	1531nm DFB	-5 ~ 0 dBm	PIN	- 22dBm (max)	AC	TTL	0~70°C	40km	CWDM
RTXM177XC-A5*	2x10 SFF	1.25G	1551nm DFB	-5 ~ 0 dBm	PIN	- 22dBm (max)	AC	TTL	0~70°C	40km	CWDM
RTXM177XC-A6*	2x10 SFF	1.25G	1571nm DFB	-5 ~ 0 dBm	PIN	- 22dBm (max)	AC	TTL	0~70°C	40km	CWDM
RTXM177XC-A7*	2x10 SFF	1.25G	1591nm DFB	-5 ~ 0 dBm	PIN	- 22dBm (max)	AC	TTL	0~70°C	40km	CWDM
RTXM177XC-A8*	2x10 SFF	1.25G	1611nm DFB	-5 ~ 0 dBm	PIN	- 22dBm (max)	AC	TTL	0~70°C	40km	CWDM
RTXM177XC-A1-P*	2x10 SFF	1.25G	1471nm DFB	-5 ~ 0 dBm	PIN	- 22dBm (max)	AC	PECL	0~70°C	40km	CWDM
RTXM177XC-A2-P*	2x10 SFF	1.25G	1491nm DFB	-5 ~ 0 dBm	PIN	- 22dBm (max)	AC	PECL	0~70°C	40km	CWDM
RTXM177XC-A3-P*	2x10 SFF	1.25G	1511nm DFB	-5 ~ 0 dBm	PIN	- 22dBm (max)	AC	PECL	0~70°C	40km	CWDM
RTXM177XC-A4-P*	2x10 SFF	1.25G	1531nm DFB	-5 ~ 0 dBm	PIN	- 22dBm (max)	AC	PECL	0~70°C	40km	CWDM
RTXM177XC-A5-P*	2x10 SFF	1.25G	1551nm DFB	-5 ~ 0 dBm	PIN	- 22dBm (max)	AC	PECL	0~70°C	40km	CWDM
RTXM177XC-A6-P*	2x10 SFF	1.25G	1571nm DFB	-5 ~ 0 dBm	PIN	- 22dBm (max)	AC	PECL	0~70°C	40km	CWDM

RTXM177XC-A7-P*	2x10 SFF	1.25G	1591nm DFB	-5 ~ 0 dBm	PIN	- 22dBm (max)	AC	PECL	0~70°C	40km	CWDM
RTXM177XC-A8-P*	2x10 SFF	1.25G	1611nm DFB	-5 ~ 0 dBm	PIN	- 22dBm (max)	AC	PECL	0~70°C	40km	CWDM
RTXM177XC-B1*	2x10 SFF	1.25G	1471nm DFB	-5 ~ 0 dBm	PIN	- 22dBm (max)	DC	TTL	0~70°C	40km	CWDM
RTXM177XC-B2*	2x10 SFF	1.25G	1491nm DFB	-5 ~ 0 dBm	PIN	- 22dBm (max)	DC	TTL	0~70°C	40km	CWDM
RTXM177XC-B3*	2x10 SFF	1.25G	1511nm DFB	-5 ~ 0 dBm	PIN	- 22dBm (max)	DC	TTL	0~70°C	40km	CWDM
RTXM177XC-B4*	2x10 SFF	1.25G	1531nm DFB	-5 ~ 0 dBm	PIN	- 22dBm (max)	DC	TTL	0~70°C	40km	CWDM
RTXM177XC-B5*	2x10 SFF	1.25G	1551nm DFB	-5 ~ 0 dBm	PIN	- 22dBm (max)	DC	TTL	0~70°C	40km	CWDM
RTXM177XC-B6*	2x10 SFF	1.25G	1571nm DFB	-5 ~ 0 dBm	PIN	- 22dBm (max)	DC	TTL	0~70°C	40km	CWDM
RTXM177XC-B7*	2x10 SFF	1.25G	1591nm DFB	-5 ~ 0 dBm	PIN	- 22dBm (max)	DC	TTL	0~70°C	40km	CWDM
RTXM177XC-B8*	2x10 SFF	1.25G	1611nm DFB	-5 ~ 0 dBm	PIN	- 22dBm (max)	DC	TTL	0~70°C	40km	CWDM
RTXM177XC-B1-P*	2x10 SFF	1.25G	1471nm DFB	-5 ~ 0 dBm	PIN	- 22dBm (max)	DC	PECL	0~70°C	40km	CWDM
RTXM177XC-B2-P*	2x10 SFF	1.25G	1491nm DFB	-5 ~ 0 dBm	PIN	- 22dBm (max)	DC	PECL	0~70°C	40km	CWDM
RTXM177XC-B3-P*	2x10 SFF	1.25G	1511nm DFB	-5 ~ 0 dBm	PIN	- 22dBm (max)	DC	PECL	0~70°C	40km	CWDM
RTXM177XC-B4-P*	2x10 SFF	1.25G	1531nm DFB	-5 ~ 0 dBm	PIN	- 22dBm (max)	DC	PECL	0~70°C	40km	CWDM
RTXM177XC-B5-P*	2x10 SFF	1.25G	1551nm DFB	-5 ~ 0 dBm	PIN	- 22dBm (max)	DC	PECL	0~70°C	40km	CWDM
RTXM177XC-B6-P*	2x10 SFF	1.25G	1571nm DFB	-5 ~ 0 dBm	PIN	- 22dBm (max)	DC	PECL	0~70°C	40km	CWDM
RTXM177XC-B7-P*	2x10 SFF	1.25G	1591nm DFB	-5 ~ 0 dBm	PIN	- 22dBm (max)	DC	PECL	0~70°C	40km	CWDM
RTXM177XC-B8-P*	2x10 SFF	1.25G	1611nm DFB	-5 ~ 0 dBm	PIN	- 22dBm (max)	DC	PECL	0~70°C	40km	CWDM

*: The product marked with * is not available at present.

WTD reserves the right to make changes to the product(s) or information contained herein without notice. No liability is assumed as a result of their use or application. No rights under any patent accompany the sale of any such product(s) or information.

Edition 2009-12-01

Published by Wuhan Telecommunication Devices Co.,Ltd.

Copyright © WTD

All Rights Reserved.