



3.3V SFF 2×5 1.25G Single Mode Transceiver Module

RTXM177 Series

Features

- *Duplex LC receptacle optical interface*
- *SFF 2x5 metallic package with EMI nose shield*
- *Distance options of 30km, 40km and 80km on 9/125 μ m SMF cables*
- *CML or PECL logic I/O interfaces*
- *TTL transmitter disable input*
- *Receiver signal detect output (TTL / PECL optional)*
- *Single + 3.3V power supply*
- *Low power consumption*

Application

- *Gigabit Ethernet*
- *Fiber Channel*

Standard

- *Compliant with SFF MSA July 5,2000*
- *Compliant with IEEE 802.3z*

Absolute Maximum Ratings

Parameter	Symbol	Unit	Min	Max
Storage Temperature	T _s	°C	- 40	+ 85
Relative Humidity	RH	%	5	95
Power Supply Voltage	V _{cc}	V	- 0.5	+ 4.0
Lead Solder Temperature	-	°C	-	260
Lead Solder Duration	-	sec	-	10

Note: Stresses in excess of absolute maximum ratings may cause damage to the device. Exposure to absolute maximum ratings for extended periods may affect device reliability.

Recommended Operating Conditions

Parameter	Symbol	Unit	Min	Typ	Max
Ambient Operating Temperature	T _A	°C	0	-	+ 70
Power Supply Voltage	V _{cc}	V	3.14	3.3	3.47

Specifications (tested under recommended operating conditions, unless otherwise noted)

Parameter	Symbol	Unit	Min	Typ	Max	Note	
Electrical Characteristics							
Supply Current	I _{cc}	mA	-	-	250		
Transmitter Differential Data Input Swing	V _{IN}	mV	400	-	2000	1	
Transmitter Disable Voltage	-	V	V _{cc} -1.3	-	V _{cc} +0.3		
Transmitter Enable Voltage	-	V	0	-	0.8		
Transmitter Disable Assert Time	t _{off}	μs	-	-	10		
Transmitter Disable Deassert Time	t _{on}	ms	-	-	1.0		
Receiver Differential Data Output Swing	V _{OUT}	mV	370	-	2000	2	
Signal Detect	High	-	V	V _{cc} -1.3	-	V _{cc} +0.3	
Output Voltage (TTL)	Low	-	V	0	-	0.8	
Signal Detect	High	-	V	V _{cc} -1.1	-	V _{cc} -0.7	
Output Voltage (PECL)	Low	-	V	V _{cc} -1.95	-	V _{cc} -1.5	
Optical Transmitter Characteristics							
Launch Optical Power	177 - A1/B1 - 1	P ₀	dBm	- 11	-	- 5	3,4
	177 - A2/B2 - 4			- 5	-	0	
	177 - A4/B4 - 4			- 4	-	+ 1	
	177 - A4/B4 - 5			- 2	-	+ 2	
Center Wavelength Range	177 - A1/B1 - 1	λ _c	nm	1260	1310	1360	
	177 - A2/B2 - 4						
	177 - A4/B4 - 4			1500	1550	1580	
	177 - A4/B4 - 5						

Extinction Ratio		E_x	dB	9.0	-	-
Spectral Width	RMS	177 - A1/B1 - 1		-	-	4
		177 - A2/B2 - 4				
	-20dB	177 - A4/B4 - 4	$\Delta\lambda$	nm	-	1
		177 - A4/B4 - 5				
Rise/Fall Time (20% ~ 80%)		tr/tf	ns	-	-	0.26
Disabled Transmitter Output Power		-	dBm	-	-	- 35
Eye Diagram				IEEE 802.3z		5
Optical Receiver Characteristics						
Receiver Sensitivity		177 - A1/B1 - 1			-	- 20
		177 - A2/B2 - 4				
		177 - A4/B4 - 4	S	dBm	-	- 22
		177 - A4/B4 - 5			-	- 22
Overload Input Optical Power			dBm	- 3	-	-
Signal Detect	Assert	177 - A1/B1 - 1			-	- 20
		177 - A2/B2 - 4				
		177 - A4/B4 - 4			-	- 22
	De-assert	177 - A4/B4 - 5	-	dBm	- 35	-
Signal Detect Hysteresis		-	dB	0.5	-	-

Note 1: AC coupled internally.

Note 2: AC or DC (optional) coupled internally.

Note 3: Minimum output optical level is at end of life (EOL).

Note 4: Coupled into 9/125 μ m SMF.

Note 5: Measured with PRBS 2⁷-1 test pattern @1.25Gbps.

Note 6: Measured with PRBS 2⁷-1 test pattern @1.25Gbps, $E_x=10$ dB, $BER \leq 10^{-12}$.

Pin Description

Pin	Name	Description
1	V_{EER}	Receiver Signal Ground
2	V_{CCR}	Receiver Power Supply
3	SD	Signal Detect (TTL/PECL optional)
		Normal Operation: logic "1" output Fault Condition: logic "0" output
4	RD-	Received Data Output Bar
5	RD+	Receiver data output
6	V_{CCT}	Transmitter Power Supply
7	V_{EET}	Transmitter Signal Ground
8	TXdis	Transmitter Disable
		Normal Operation: logic "0" or Open Circuit --Laser On Transmit Disabled: logic "1" --Laser Off

9	TD+	Transmitter Data In
10	TD-	Transmitter data In Bar

Block Diagram

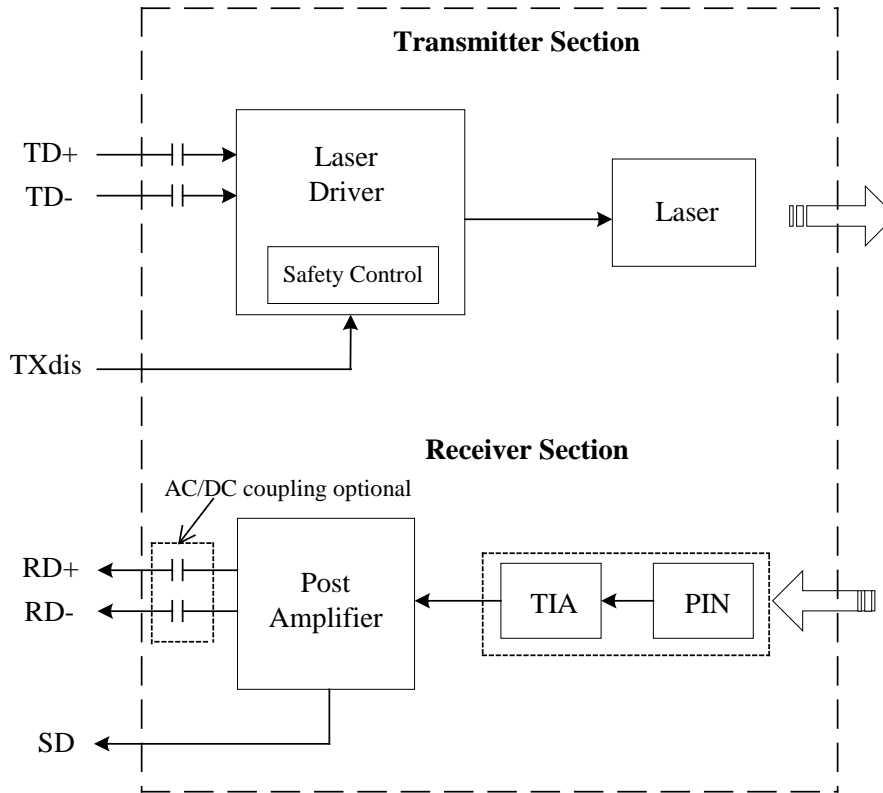

Typical Application Circuit

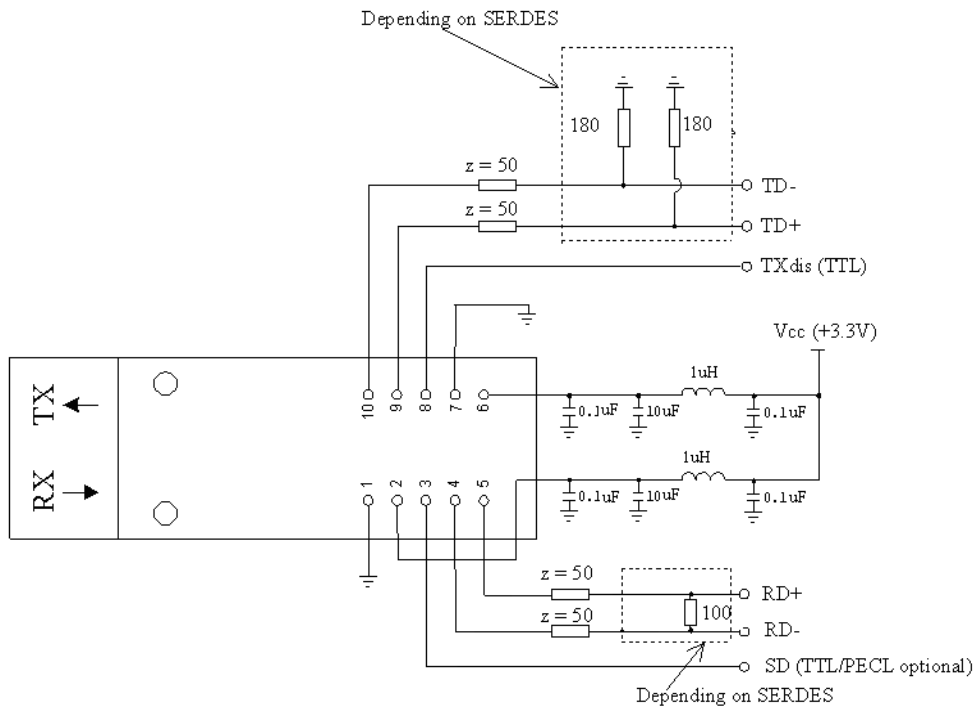

AC coupling (internal)

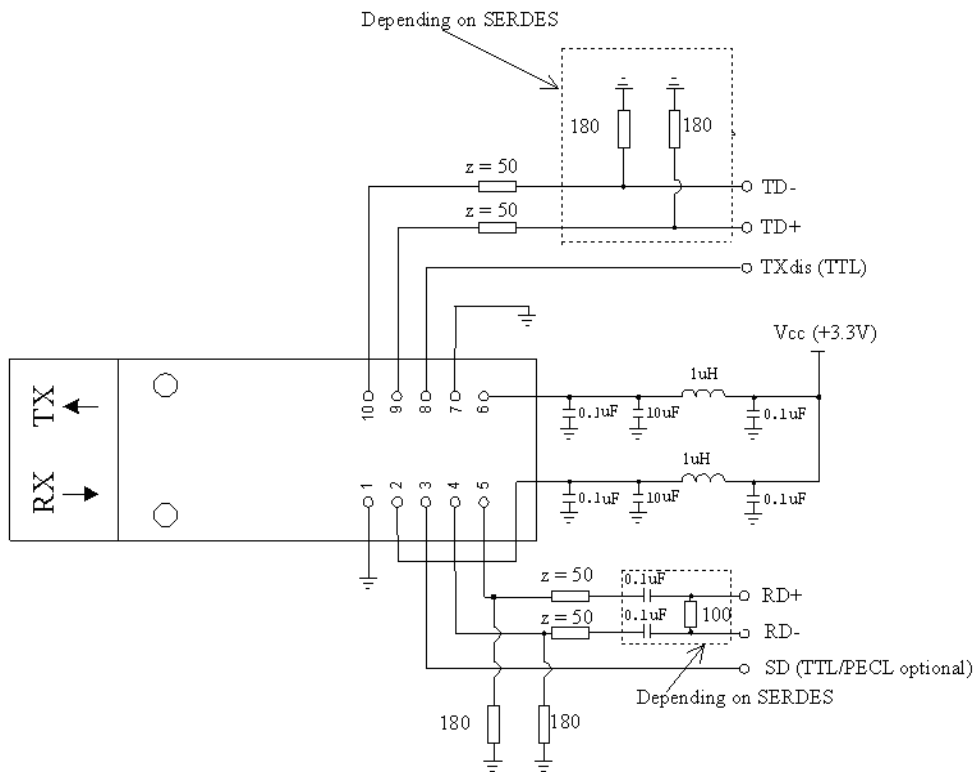

DC coupling (internal)

Package Outline (units in mm)

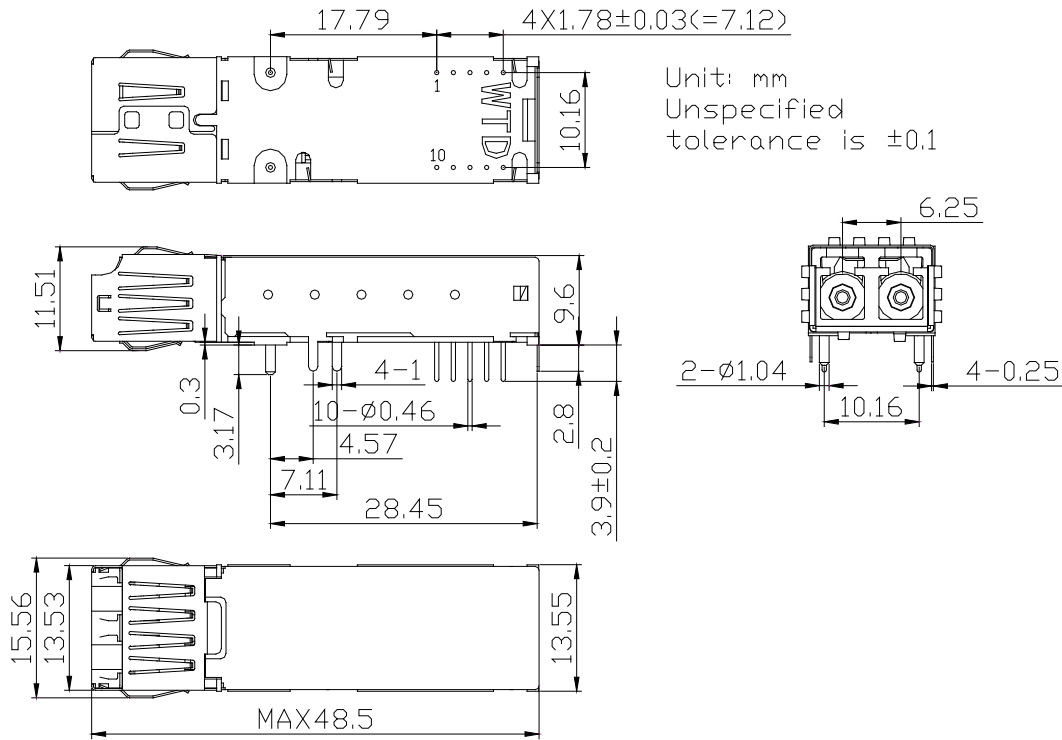

Regulatory Compliance

Feature	Test Method	Performance
Electrostatic Discharge (ESD) to the Electrical Pins	MIL-STD-883E Method 3015.7	Class 1 (>1.5kV) – Human Body Model
Electrostatic Discharge (ESD) Immunity	IEC61000-4-2	Class 2 (>4.0kV)
Electromagnetic Interference (EMI)	CISPR22 ITE Class B EN55022 Class B	Compliant with standards
Immunity	IEC61000-4-3 Class 2 EN55024	Typically show no measurable effect from a 3V/m field swept from 80 to 1000MHz applied to the transceiver without a chassis enclosure.
Eye Safety	FDA 21 CFR 1040.10 and 1040.11 UL TUV EN 60825-1	Compliant with Class I, CDRH/IEC 825 UL file E239070

Ordering Information

Part No.	Specifications										Application
	Pack	Rate	Tx	Pout	Rx	S	Top	Reach	Others		
RTXM177-A1-1	2x5 SFF	1.25G	1310nm FP	-11 ~ -5dBm	PIN < -20dBm	0~70°C	30km	AC, TTL		1000BASE-LH	
RTXM177-A1-1-P	2x5 SFF	1.25G	1310nm FP	-11 ~ -5dBm	PIN < -20dBm	0~70°C	30km	AC,PECL		1000BASE-LH	
RTXM177-B1-1	2x5 SFF	1.25G	1310nm FP	-11 ~ -5dBm	PIN < -20dBm	0~70°C	30km	DC,TTL		1000BASE-LH	
RTXM177-B1-1-P	2x5 SFF	1.25G	1310nm FP	-11 ~ -5dBm	PIN < -20dBm	0~70°C	30km	DC,PECL		1000BASE-LH	
RTXM177-A2-4*	2x5 SFF	1.25G	1310nm DFB	-5 ~ 0dBm	PIN < -20dBm	0~70°C	40km	AC,TTL		1000BASE-LH1	
RTXM177-A2-4-P*	2x5 SFF	1.25G	1310nm DFB	-5 ~ 0dBm	PIN < -20dBm	0~70°C	40km	AC,PECL		1000BASE-LH1	
RTXM177-B2-4*	2x5 SFF	1.25G	1310nm DFB	-5 ~ 0dBm	PIN < -20dBm	0~70°C	40km	DC,TTL		1000BASE-LH1	
RTXM177-B2-4-P*	2x5 SFF	1.25G	1550nm DFB	-5 ~ 0dBm	PIN < -20dBm	0~70°C	40km	DC,PECL		1000BASE-LH1	
RTXM177-A4-4	2x5 SFF	1.25G	1550nm DFB	-4 ~ +1dBm	PIN < -22dBm	0~70°C	40km	AC,TTL		1000BASE-LH2	
RTXM177-A4-4-P	2x5 SFF	1.25G	1550nm DFB	-4 ~ +1dBm	PIN < -22dBm	0~70°C	40km	AC,PECL		1000BASE-LH2	
RTXM177-B4-4	2x5 SFF	1.25G	1550nm DFB	-4 ~ +1dBm	PIN < -22dBm	0~70°C	40km	DC,TTL		1000BASE-LH2	
RTXM177-B4-4-P*	2x5 SFF	1.25G	1550nm DFB	-4 ~ +1dBm	PIN < -22dBm	0~70°C	40km	DC,PECL		1000BASE-LH2	
RTXM177-A4-5	2x5 SFF	1.25G	1550nm DFB	-2 ~ +2dBm	PIN < -22dBm	0~70°C	80km	AC,TTL		1000BASE-ZX	
RTXM177-A4-5-P*	2x5 SFF	1.25G	1550nm DFB	-2 ~ +2dBm	PIN < -22dBm	0~70°C	80km	AC,PECL		1000BASE-ZX	
RTXM177-B4-5*	2x5 SFF	1.25G	1550nm DFB	-2 ~ +2dBm	PIN < -22dBm	0~70°C	80km	DC,TTL		1000BASE-ZX	
RTXM177-B4-5-P*	2x5 SFF	1.25G	1550nm DFB	-2 ~ +2dBm	PIN < -22dBm	0~70°C	80km	DC,PECL		1000BASE-ZX	

*: The product marked with * needs further confirmation with sales upon each order

WTD reserves the right to make changes to the product(s) or information contained herein without notice. No liability is assumed as a result of their use or application. No rights under any patent accompany the sale of any such product(s) or information.

Edition 2009-12-01

Published by Wuhan Telecommunication Devices Co.,Ltd.

Copyright © WTD

All Rights Reserved.