

BPON ONU Triplexer Transceiver

RTXM170-513

Features

- *Single fiber triplexer incorporates a symmetric 1.25Gbps upstream/1.25Gbps downstream and 45~875MHz CATV analog signal.*
- *Burst mode transmission with 1310nm FP laser.*
- *Continuous mode digital receiver with 1490nm high sensitivity PIN-TIA.*
- *Analog CATV receiver with 1550nm high linearity and high responsivity InGaAs PIN detector.*
- *0~ +70°C operating ambient temperature.*
- *Compact package with single mode fiber pigtailed SC/APC connector*
- *+3.3V / +5V / +12V power supply*
- *LVPECL compatible data input and data output*
- *LVTTL transmitter burst-mode control*
- *LVTTL transmitter disable control*
- *LVTTL digital receiver SD indication*
- *CATV receiver input optical power monitor*

- *and SD output*
- *Low EMI and excellent ESD/TVS*
- *protection*
- *RoHS compliance*

Application

- *GEAPON ONU Side*

Standards

- *Compliant with IEEE Std 802.3ahTM -2004 1000BASE-PX10-U*
- *Compliant with FCC 47 CFR Part 15, Class B*
- *Compliant with FDA 21 CFR 1040.10 and 1040.11, Class I*

Description

RTXM170-513 is Optical Network Unit (ONU) for FTTH networks 10km transmission.

The Triplexer comprise of a Burst Mode optical transmitter , a Continuous Mode optical receiver and a CATV receiver.

The Digital transmitter and receiver is the high performance module for 1.25Gbps upstream and downstream data rate. The transmitter incorporates an Automatic Power Control(APC) circuit and an Automatic Temperature Control(ATC) circuit to maintain the optical power and extinction ratio over a operating temperature of 0~+70 °C.

The CATV receiver is incorporated in the Tri-Transceiver with a SMB Male. It contains an Automatic Gain Control(AGC) circuit to maintain the output effective voltage level over an input optical power range of -6dBm~+2dBm and contains a Spectrum Balance Network(SBN) circuit to maintain the output voltage level over a wideband of 45MHz~875MHZ.

Block Diagram

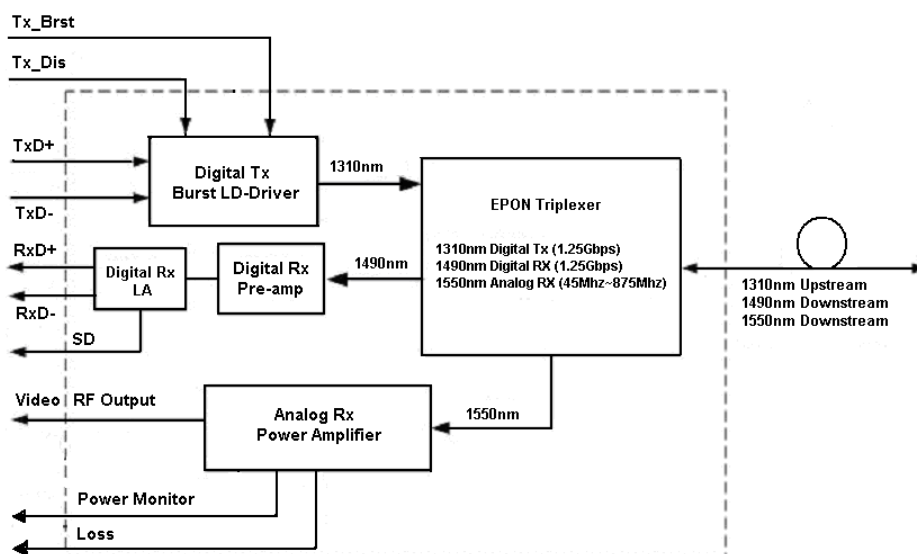

Absolute Maximum Ratings

Parameter	Symbol	Unit	Min	Max
Storage Temperature Range	Ts	°C	-40	+85
Operating Temperature Range	To	°C	0	+70
Relative Humidity	RH	%	5	95
Power Supply voltage	Video Receiver PD	Vcc_Pd	V	+15
	Video Receiver Amplifier	Vcc_Amp	V	+5.5
	Digital Transmitter	Vcc_TX	V	+4
	Digital Receiver	Vcc_RX	V	+4
Video Receiver Damaged Threshold	-	dBm		+3
Digital Receiver Damaged Threshold	-	dBm		+7
Lead soldering temperature	-	°C		260
Lead soldering duration	-	S		10
Bending Radius of pigtail fiber	-	mm	30	
Tensile force on pigtail		kg	1.0	
RF Connector			SMB Jack Connector	
Fiber Connector			SC/APC	

Recommended Operating Conditions

Parameter	Symbol	Unit	Min	Type	Max	
Case Operating Temperature Range	Tc	°C	0		+70	
Relative Humidity	RH	%	5		95	
Power Supply Voltage	Video Receiver PD	Vcc_Pd	V	+10	+12	+15
	Video Receiver Amplifier	Vcc_Amp	V	+4.8	+5	+5.5
	Digital Transmitter	Vcc_TX	V	+3.13	+3.3	+3.47
	Digital Receiver	Vcc_RX	V	+3.13	+3.3	+3.47
Power Supply Current	Video Receiver PD	Icc_Pd	mA			10
	Video Receiver Amplifier	Icc_Amp	mA		260	320
	Digital Transmitter	Icc_TX	mA			200
	Digital Receiver	Icc_RX	mA			120
Digital Receiver Data Rate		Mbps		1250		
Data Rate Drift		ppm	-100		+100	
Analog Receiver Frequency		Mhz	45		875	

Optical and Electrical Specifications

Digital Transmitter Optical and Electrical Specifications ($0 < T < +70$ oC, $3.13V < V_{cc} < 3.47V$)

Digital Transmitter Characteristics

Parameter	Symbol	Unit	Min	Typ	Max	Test condition
Power Supply Voltage	V _{cc-Tx}	V	3.135	3.3	3.465	-
Power Supply Current	I _{cc-Tx}	mA	-	-	200	-
Operation Wavelength	λ_p	nm	1280	1310	1350	CW
Spectral Width	$\Delta\lambda$	nm	-	-	3	RMS
Average Optical Output Power	P _o	dBm	-1	-	+4	-
Extinction ratio (1)	ER	dB	10	-	-	-
Bit Rate		Mbps		1250		CW
Average Optical Power Output with Bias Control OR TX Disabled	P _O disable	dBm	-	-	-45	-
Burst turn on Time (2)		ns	-	-	16	-
Burst turn off Time (2)		ns	-	-	16	-
Rise/Fall time (1)		ps	-	-	260	-
Input Differential Voltage(3)		mv	200		1600	-
Input Differential Impedance	Z _i	Ω	90	100	110	-
Transmitter Eye Diagram	Compliant with IEEE Std 802.3 <i>ah</i> TM					-2004

Note1: Measured with PRBS²⁷-1 test pattern @ 1.25Gbps

Note2: Refer to Timing Parameter Definition in Burst Mode Sequence

Note3: Compatible with LVPECL input

Digital Receiver Optical and Electrical Specifications ($0 < T < +70$ oC, $3.13V < V_{cc} < 3.47V$)

Digital Receiver Characteristics

Parameter	Symbol	Unit	Min	Typ	Max	Test condition
Power Supply Voltage	V _{cc-Rx}	V	3.135	3.3	3.465	-
Power Supply Current	I _{cc-Rx}	mA	-	-	120	-
Operation Wavelength	λ_p	nm	1480	1490	1500	CW
Sensitivity (1)	P _{sen}	dBm	-	-	-25	1.25Gb/s, Full Duplex, BER \leq 10 ⁻¹²
Saturation Input Power	P _{sat}	dBm	-3	-	-	
Signal Detect Assert Level (2)	P _{sda}	dBm	-	-	-26	
Signal Detect Deassert Level (3)	P _{sdd}	dBm	-40	-	-	
Signal Detect Hysteresis	P _{sda} - P _{sdd}	dB	0.5		6	
Bit Rate		Mbps	-	1250		CW
Output Differential Voltage(4)		mv	200		1600	-
Output Differential Impedance	Z _o	Ω	90	100	110	-

Signal Detect Assert Time	T _{ass}	us	10	-
Signal Detect Deassert Time	T _{das}	us	10	-
Jitter		-	Compliant with ITU-T G.983.3	

Note1: Measured with PRBS²⁷-1 test pattern @ 1.25Gbps and ER=10dB, BER=1×10⁻¹².

Note2: An increase in optical power above the level will cause the Signal Detect output to switch from a low state to a high state.

Note3: An decrease in optical power below the level will cause the Signal Detect output to switch from a high state to a low state.

Note4: Compatible with LVPECL output(AC coupled internally).

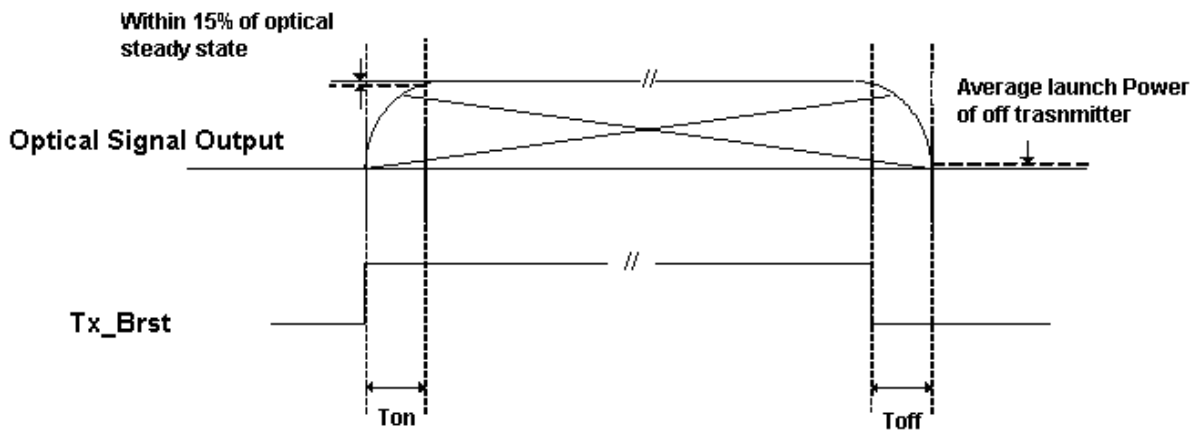

Figure 1 Timing Parameter Definition in Burst Mode Sequence

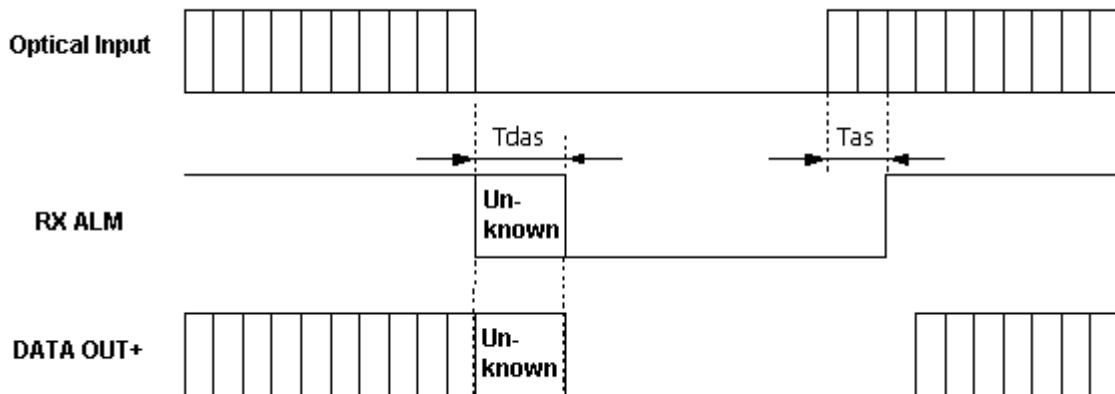

Figure 2 Timing Parameter Definition of RX ALM Assert/Deassert time

Analog CATV Receiver Optical and Electrical Specifications
 (0<T<+70 oC, 4.75V< V_{cc-Amp}<5.25V, 11.4V< V_{cc-Pd}<12.6V)

Video Receiver Characteristics

Parameter	Symbol	Unit	Min	Typ	Max	Test condition
Power Supply Voltage	V _{cc-Pd}	V	+10	+12	+15	-
	V _{cc-Amp}	V	+4.8	+5	+5.5	-
Power Supply current	I _{cc-Pd}	mA	-	260	320	-

	Icc-Amp	mA	-	-	10	-
Operation Wavelength	λ_p	nm	-	1550	-	CW
Input Optical Power Dynamic Range	Pin	dBm	-6	-	+2	-
Optical Return loss	-	dB	45	-	-	-
RF output level	-	dBuv	-	76	-	Note1
Flatness in band	-	dB	-	± 1	-	-
CNR	CNR	dB	46	-	-	Note2
C/CSO	CSO	dBc	55	-	-	Note3
C/CTB	CTB	dBc	56	-	-	
Output Return Loss	-	dB	14	-	-	-
Output Impedance	Ro	Ω	-	75	-	-

Note1: Test at Optical Input Power -6dBm, 551.25Mhz, OMI=3.5%

Note2: Test at Optical Input Power -6dBm, 84 PAL-D channels, OMI=3.5% per channel

Note3: Test at Optical Input Power +2dBm, 84 PAL-D channels, OMI=3.5% per channel

Typical Application Circuit

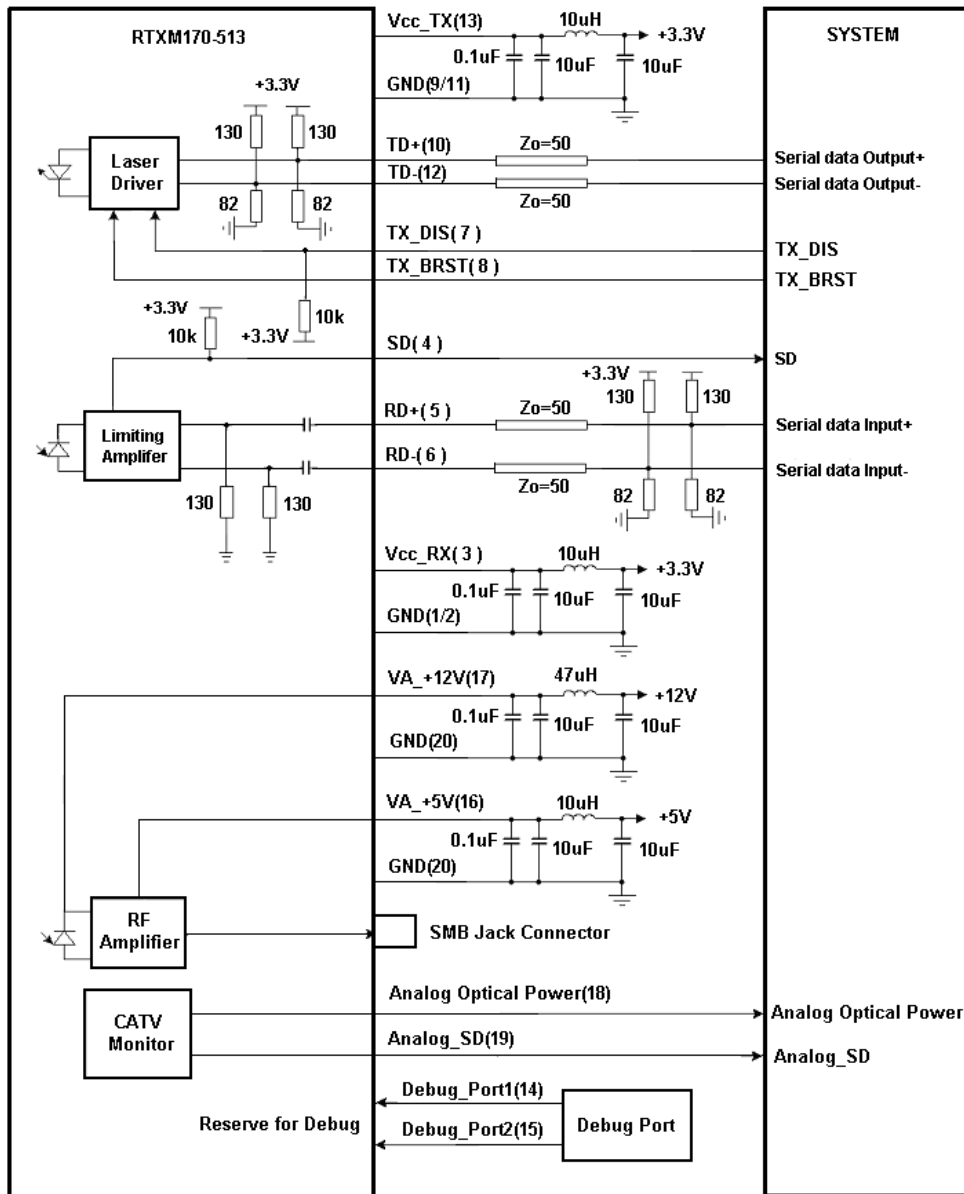
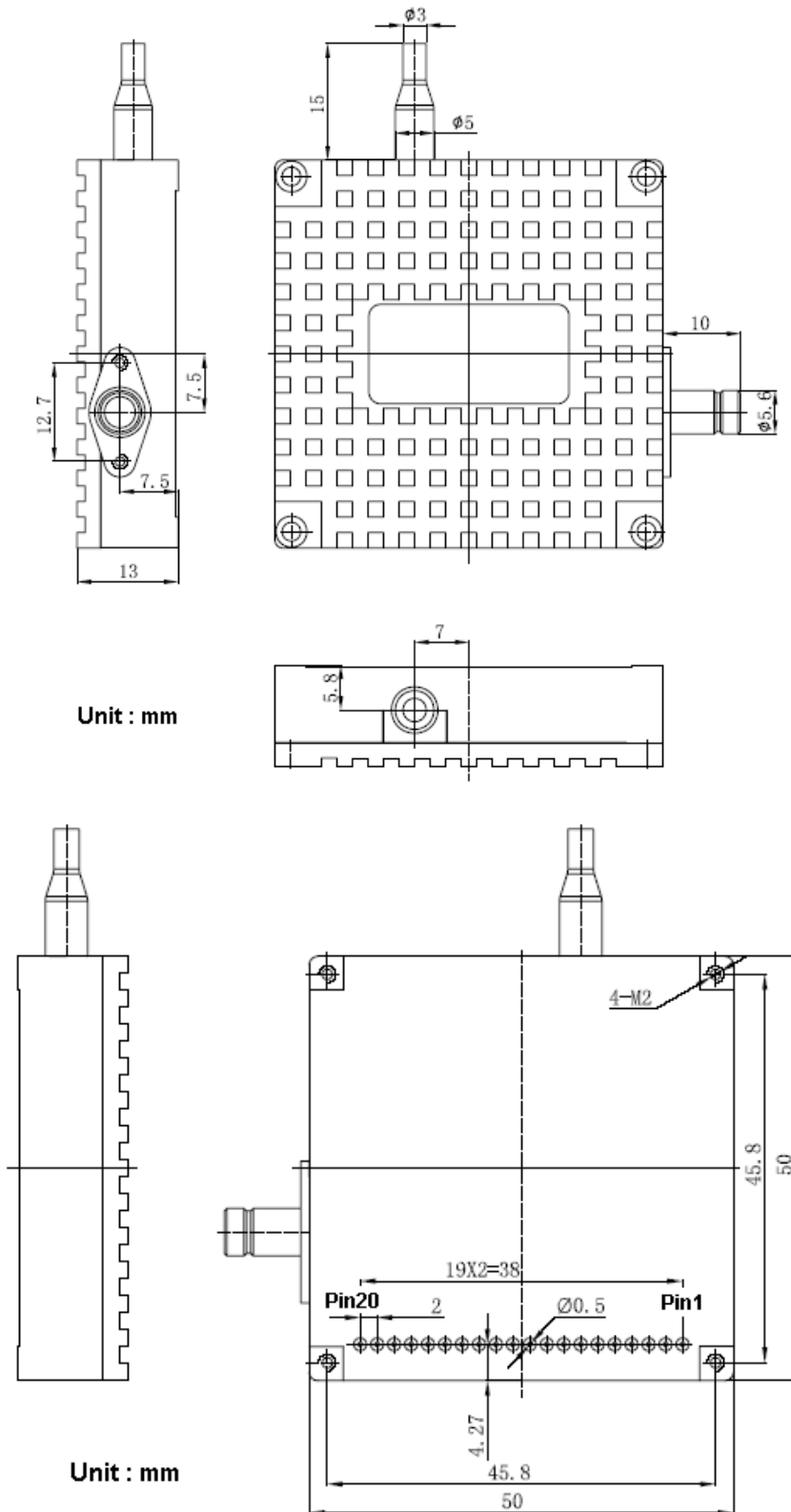

Figure 3 Typical Interface Circuit

Package Outline



Unit : mm

Unit : mm

Note: The form factor is 20PIN compact package with pigtail fiber. The pigtail fiber has a length of 1000 ± 100 mm and 30mm minimum bending radius. The fiber connector type is SC/APC.

Pin Description

PIN No.	Name	Description	Notes
1	GND	Signal Ground	
2	GND	Signal Ground	
3	Vcc_RX	Digital Receiver Power Supply (+3.3V)	
4	SD	Digital Receiver Signal-Detected Indication	1
5	RD+	Noninverting Receiver Data Output	2
6	RD-	Inverting Receiver Data Output	
7	TX_DIS	Transmitter Disable	3
8	TX_BRST	Transmitter Burst Control	4
9	GND	Signal Ground	
10	TD+	Noninverting Transmitter Data Output	5
11	GND	Signal Ground	
12	TD-	Inverting Transmitter Data Output	5
13	Vcc_TX	Digital Transmitter Power Supply (+3.3V)	
14	Debug Port1	Reserved for Module Debugging	6
15	Debug Port2	Reserved for Module Debugging	
16	VA_+5V	CATV Receiver Power Supply (+5V)	
17	VA_+12V	CATV Receiver Power Supply (+12V)	
18	Analog Optical Power	Analog Receiver Optical Power Monitor Output	7
19	Analog_SD	Analog Receiver Signal-Detected Indication	8
20	GND	Signal Ground	
SMB	RF Output	CATV Receiver RF Analog Output (75Ω)	9

Note1: LVTTTL logic output, with internal 10KΩ pull-up resistor.

Optical Signal-Detected: High; Optical Signal Loss: Low

Note2: LVPECL logic output, AC coupled internally.

Note3: LVTTTL logic input, with internal 10KΩ pull-up resistor

Transmitter Disable: High; Transmitter Enable: Low

Note4: A positive level enable optical signal output under burst mode.

Note5: Compatible with LVPECL input, DC coupled internally.

Note6: Reserved for module's debugging. No connect to it.

Note7: Analog output voltage, it can be used to indicate the CATV receiver input optical power.

Note8: Analog output voltage, it can be used to indicate the CATV receiver Loss.

Optical Power > -8dBm: High; Optical Power < -8dBm: Low

Note9: SMB Jack connector

Regulatory Compliance

Feature	Standard	Performance
Electrostatic Discharge(ESD) to the Electrical Pins	MIL-STD-883E Method 3015.7	Class 1(>1.5KV) Human Body Model
Electrostatic Discharge (ESD) Immunity	IEC61000-4-2	Class 2(>4.0kV)
Electromagnetic Interference (EMI)	CISPR22 ITE Class B EN55022 Class B	Compliant with standards
Immunity	IEC61000-4-3 Class 2 EN55024	Compliant with standards
Laser Eye Safety	FDA 21 CFR 1040.10 And 1040.11 EN60950,EN(IEC) 60825-1,2	Compliant with Class 1 laser product
	GR-468 –CORE GR-1089-CORE GR-78-CORE	

Ordering Information

Part No	Specification								Application
	Package	Rate	Laser	Optical Power	Detector	Sensitivity	Temp	Reach	
RTXM170-513	1×20 Triplexer	Tx: .25Gbps Rx: 1.25Gbps CATV: 45~875MHZ	1310nm FP-LD	-1~+4dBm	1490nm PIN-TIA 1550nm PIN	<-25dBm	0~+70°C	10km	EPON ONU

WTD reserves the right to make changes to the product(s) or information contained herein without notice. No liability is assumed as a result of their use or application. No rights under any patent accompany the sale of any such product(s) or information.

Edition 2009-12-1

Published by Wuhan Telecommunication Devices Co.,Ltd.

Copyright © WTD

All Rights Reserved.