



10km EPON ONU Optical Transceiver SFF Module

RTXM169-407

Features

- *Integrated Single fiber bi-directional optical subassembly*
- *SC receptacle optical interface*
- *1310nm FP laser Burst-mode Transmitter and 1490nm PIN/TIA Continuous receiver(with WDM)*
- *SFF 2x5 metallic package*
- *+3.3V single power supply*
- *Low power consumption*
- *0 to 70°C operating ambient temperature*
- *LVPECL compatible data input/output interface*
- *LVTTL transmitter burst mode control*
- *LVTTL receiver signal-detected indication*
- *Class 1 Laser eye safety*
- *RoHS compliant*

Application

- *Optical transceiver for Gigabit Ethernet Passive Optical Networks (EPON) ONU side*

Standard

- *IEEE802.3ah 1000BASE-PX10-U*
- *Small Form Factor Transceiver Multisource Agreement July 5,2000*

Description

The EPON ONU Transceiver module is designed for Gigabit Ethernet Passive Optical Network (EPON) 10km transmission. The module incorporates 1310nm burst-mode transmitter and 1490nm continuous-mode receiver.

The transmitter section uses a 1310nm FP laser and an integrated BM laser driver which is designed to perform very small burst enable/disable delay time. The laser driver also includes digital APC and temperature compensation circuit, which are used for keeping the launch optical power and extinction ratio constant over temperature and aging.

The receiver section uses an integrated 1490nm InGaAs PIN photodiode and preamplifier mounted together. It has the function that indicates receiver signal-detected status (active high).

An integrated WDM coupler can separate 1490nm input light and 1310nm output light.

Absolute Maximum Ratings

Parameter	Symbol	Unit	Min	Max
Operating Temperature Range	T _c	°C	0	70
Storage Temperature Range	T _s	°C	-40	85
Relative Humidity	RH	%	5	95
Power Supply Voltage	V _{cc}	V	0	4.6
Pin Input Voltage		V	GND	V _{cc}
Receiver Damage Threshold		dBm	+4	-
Lead Solder Temperature		°C	-	260
Lead Solder Duration		S	-	10

Recommended operating conditions

Parameter	Symbol	Unit	Min	Typ	Max
Operating Voltage	V _{cc}	V	3.13	3.3	3.47
Operating Temperature Range	Top	°C	0	-	70
Operating Data Rate		Gbps	-	1.25± 100ppm	-

Specifications ($0^{\circ}\text{C} < T_{op} < 70^{\circ}\text{C}$ and $3.13\text{V} < V_{cc} < 3.47\text{V}$)

Parameter	Symbol	Unit	Min	Typ	Max	Notes
Electrical Characteristics						
Supply Current	I_{cc}	mA	–	–	300	
LVPECL Single Ended Data Input Swing		mV	100	–	800	1
LVPECL Single Ended Data Output Swing		mV	300	–	500	2
Differential Data input impedance		Ω	–	100	–	1
Signal Level(LVTTL H)		V	2.4	–	V_{cc}	
Signal Level(LVTTL L)		V	0	–	0.8	
Optical transmitter Characteristics						
Data Rate		Mbps	–	1250	–	
Center Wavelength Range	λ_c	nm	1280	–	1350	
Spectral Width(@RMS)	$\Delta\lambda$	nm	–	–	3	
Launch Optical Power	P_o	dBm	-1	–	+4	3
Off level light		dBm	–	–	-45	
Extinction Ratio	EX	dB	10	–	–	4
Burst turn on/off time	Ton/Toff	ns		16		5
Rise/Fall time(20%~80%)	Tr/Tf	ps	–	–	260	6
RIN15OMA		dB/Hz	–	–	-113	
Optical Return Loss Tolerance		dB	–	–	15	
Maximum reflectance		dB	–	–	-12	$\lambda=1.31\mu\text{m}$
Transmitter dispersion penalty	TDP	dB	–	–	1.8	7
Eye Diagram	Compliant with IEEE Std 802.3ah					8
Optical receive Characteristics						
Data Rate		Mbps	–	1250	–	
Receiver Sensitivity	S	dBm	–	–	-25	9
Overload Input Optical Power	Pin	dBm	-3	–	–	9
Center Wavelength Range	λ_c	nm	1480	1490	1500	
Receiver reflectance		dB	–	–	-12	$\lambda=1.49\mu\text{m}$
SD(LVTTL)	Optical Dessert	dBm	-44	–	–	
	Optical Assert		–	–	-26	
LOS Hysteresis		dB	0.5	–	6	

Note1: DC coupled internally and terminated externally (see the recommended circuit below).

Note2: LVPECL output, AC coupled internally(see the recommended circuit below).

Note3: Coupled into 9/125 SMF

Note4: Measured with PRBS 27-1 test pattern @1.25Gbps.

Note5: See Figure 1.

Note6: Measured with the Bessel-Thompson filter OFF.

Note7: Transmit on 10km SMF.

Note8: See Figure 2.

Note9: Measured with PRBS 27-1 test pattern @1.25Gbps with Tx on, ER=10dB, BER=10E-12.

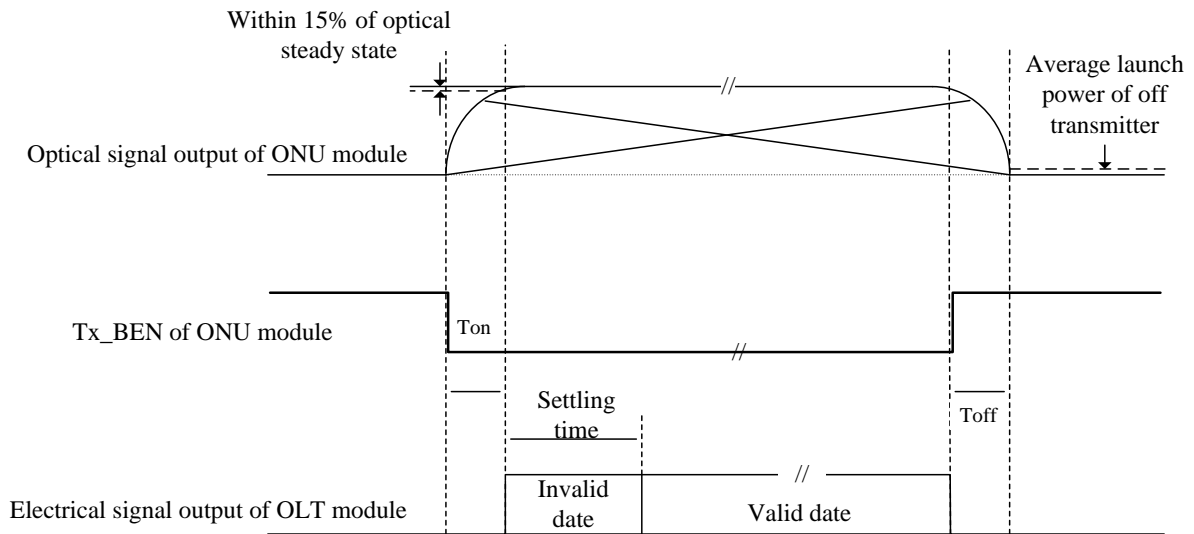
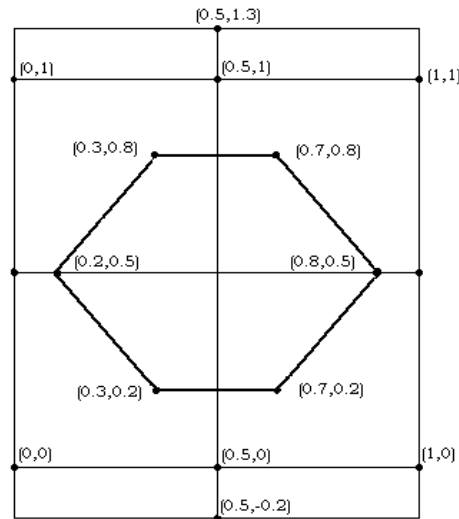

Figure 1 Burst mode Receiver Dynamic range in EPON system



Mask of diagram

Figure 2 Mask of diagram

Pin Description

Pin Name	Description	Pin Name	Description
1	Rx GND Receiver ground	6	Tx V _{CC} Transmitter power supply
2	Rx V _{CC} Receiver power supply	7	Tx GND Transmitter ground
3	SD LVTTTL Signal detect	8	Tx Dis LVTTTL Transmitter burst mode control, "H": Tx OFF
4	RD- Receiver data output- (AC coupled internally)	9	TD+ LVPECL Data input+ (DC coupled and external termination needed)
5	RD+ Receiver data output+ (AC coupled internally)	10	TD- LVPECL Data input- (DC coupled and external termination needed)

Block diagram

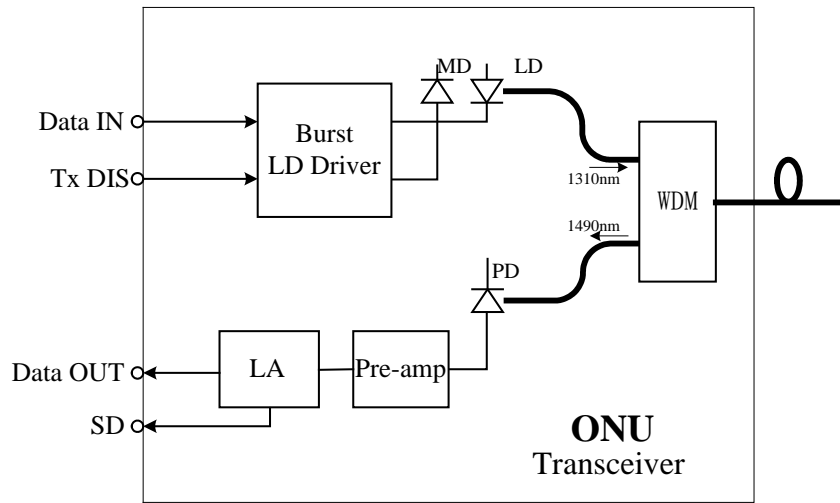

Figure 3 Functional block diagram

Typical application circuit

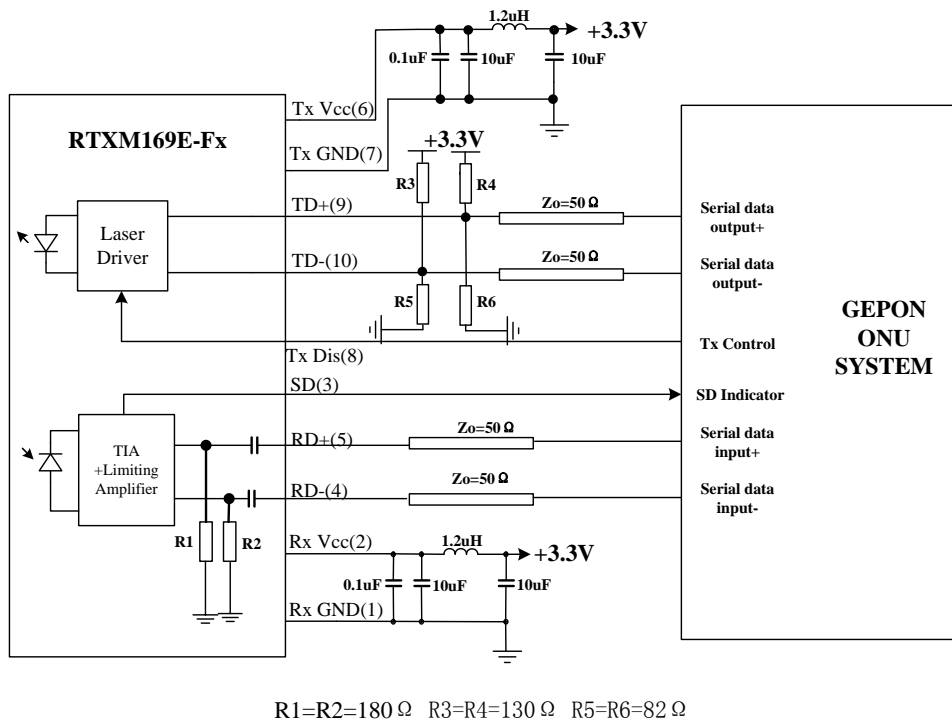

Figure 4 typical application circuits

Package outline

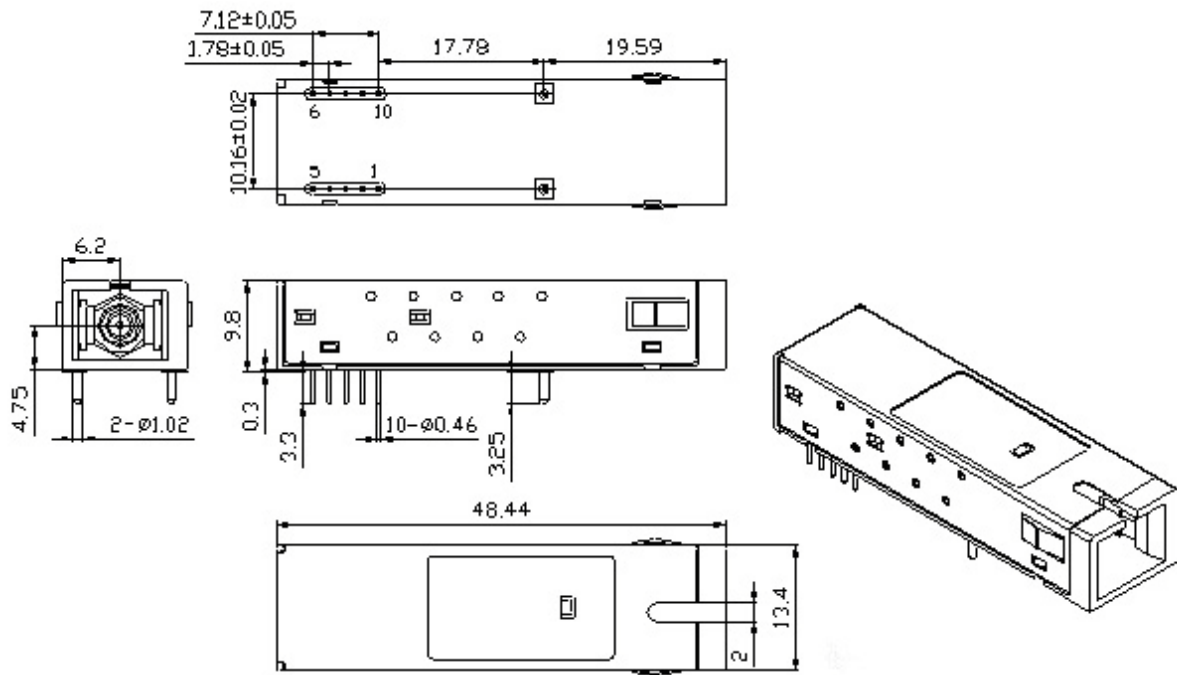

Figure 5 Package outline

Regulatory Compliance

Feature	Test Method	Performance
Electrostatic Discharge (ESD) to the Electrical Pins	MIL-STD-883E Method 3015.7	Class 1 (>1.5kV) – Human Body Model
Electrostatic Discharge (ESD) Immunity	IEC61000-4-2	Class 2(>4.0kV)
Electromagnetic Interference (EMI)	CISPR22 ITE Class B EN55022 Class B	Compliant with standards
Immunity	IEC61000-4-3 Class 2 EN55024	Typically show no measurable effect from a 3V/m field swept from 80 to 1000MHz applied to the transceiver without a chassis enclosure.
Eye Safety	FDA 21 CFR 1040.10 and 1040.11 UL TUV EN 60825-1	Compliant with Class 1 laser product

Ordering information

Part No.	Specifications										Application
	Package	Datarate	Laser	Optical Power	Detector	Sensitivity	Temp	Reach	others	Code	
RTXM169-407	SFF 2×5	1.25Gb/s	1310nm FP	-1 ~ +4dBm	PIN	< -25dBm	0~70°C	10km	TxDIS1	1000BASE-PX10-U	

Note1: The "LVTTTL transmitter burst mode control" is set as "Tx Disable at high level"

WTD reserves the right to make changes to the product(s) or information contained herein without notice. No liability is assumed as a result of their use or application. No rights under any patent accompany the sale of any such product(s) or information.

Edition 2009-12-01

Published by Wuhan Telecommunication Devices Co.,Ltd.

Copyright © WTD

All Rights Reserved.