



## 20km EPON ONU Optical SFF Transceiver

### RTXM169-404

---

#### Features

- *Integrated Single fiber bi-directional optical subassembly*
- *1310nm DFB laser Burst-mode Transmitter and 1490nm PIN/TIA Continuous receiver(with WDM)*
- *SFF 2x5 metallic package*
- *+3.3V single power supply*
- *Low power consumption*
- *0 to 70oC operating ambient temperature*
- *LVPECL compatible data input/output interface*
- *LVTTL transmitter burst mode control*
- *Tx EN*
- *LVTTL receiver signal-detected indication*
- *Class 1 Laser eye safety standard*
- *Excellent EMI and EMC characteristics*
- *ESD protection function*
- *RoHs compliant*

## Application

- *Optical transceiver for Gigabit Ethernet Passive Optical Networks (EPON) ONU side*

## Standard

- *IEEE802.3ah 1000BASE-PX20*
- *Small Form Factor Transceiver Multisource Agreement July 5,2000*

## Absolute Maximum Ratings

Parameter	Symbol	Unit	Min	Max
Operating Temperature Range	Tc	°C	0	70
Storage Temperature Range	Ts	°C	-40	85
Relative Humidity	RH	%	5	95
Power Supply Voltage	Vcc	V	0	4.6
Pin Input Voltage		V	GND	Vcc
Receiver Damage Threshold		dBm	+4	–
Lead Solder Temperature		°C	–	260
Lead Solder Duration		S	–	10

## Recommended operating conditions

Parameter	Symbol	Unit	Min	Typ	Max
Operating Voltage	Vcc	V	3.13	3.3	3.47
Operating Temperature Range	Top	°C	0	–	70
Operating Data Rate	Gbps		–	1.25±100ppm	–

## Specifications (0°C < Top < 70°C and 3.13V < Vcc < 3.47V)

Parameter	Symbol	Unit	Min	Typ	Max	Notes
<b>Electrical Characteristics</b>						
Supply Current	Icc	mA	–	–	300	
LVPECL Single Ended Data Input Swing		mV	100	–	800	1
LVPECL Single Ended Data Output Swing		mV	300	–	500	2
Differential Data input impedance		Ω	–	100	–	1
Signal Level(LVTTL H)		V	2.4	–	Vcc	
Signal Level(LVTTL L)		V	0	–	0.8	
<b>Optical transmitter Characteristics</b>						
Data Rate		Mbps	–	1250	–	
Center Wavelength Range	λc	nm	1280	–	1350	

Spectral Width(@RMS)	$\Delta\lambda$	nm	-	-	1	
Launch Optical Power	Po	dBm	0	-	+4	3
Off level light		dBm	-	-	-45	

<b>Extinction Ratio</b>	<b>EX</b>	<b>dB</b>	<b>10</b>	<b>-</b>	<b>-</b>	<b>4</b>
Burst turn on/off time	Ton/Toff	ns			16	5
Rise/Fall time(20%~80%)	Tr/Tf	ps	-	-	260	6
RIN15OMA		dB/Hz	-	-	-113	
Optical Return Loss Tolerance		dB	-	-	15	
Maximum reflectance		dB	-	-	-12	$\lambda=1.31\mu\text{m}$
Transmitter dispersion penalty	TDP	dB	-	-	1.8	7
Eye Diagram	Compliant with IEEE Std 802.3ah					8

#### Optical receive Characteristics

Data Rate		Mbps	-	1250	-	
Receiver Sensitivity	S	dBm	-	-	-25	9
Overload Input Optical Power	Pin	dBm	-3	-	-	9
Center Wavelength Range	$\lambda_c$	nm	1480	1490	1500	
Receiver reflectance		dB	-	-	-12	$\lambda=1.49\mu\text{m}$
SD(LVTTL)	Optical Dessert	dBm	-44	-	-	
	Optical Assert		-	-	-26	
LOS Hysteresis		dB	0.5	-	6	

**Note1:** DC coupled internally and terminated externally (see the recommended circuit below).

**Note2:** LVPECL output, AC coupled internally (see the recommended circuit below).

**Note3:** Coupled into 9/125 SMF

**Note4:** Measured with PRBS 27-1 test pattern @1.25Gbps.

**Note5:** see Figure 1. For RTX169E-FL, the Tx\_BEN is in reverse order.

**Note6:** Measured with the Bessel-Thompson filter ON.

**Note7:** Transmit on 20km SMF.

**Note8:** See Figure 2.

**Note9:** Measured with PRBS 27-1 test pattern @1.25Gbps with Tx on, ER=10dB, BER=10E-12.

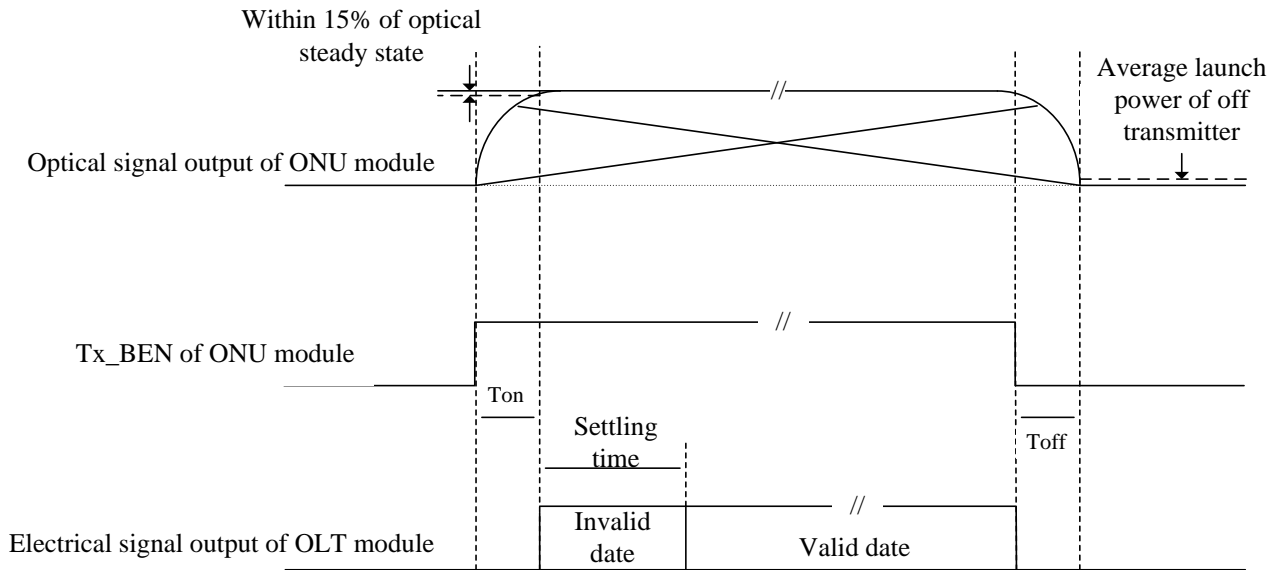

**Figure1 Burst\_mode Receiver Dynamic range in EPON system**

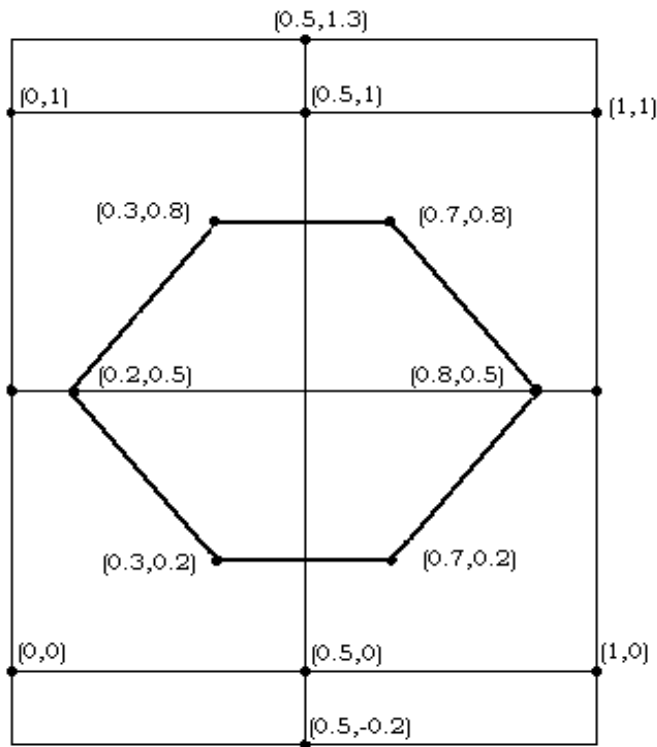

**Mask of diagram**

**Figure2 Mask of diagram**

## Pin Description

Pin Name	Description	Pin Name	Description
1	Rx GND Receiver ground	6	Tx V <sub>CC</sub> Transmitter power supply
2	Rx V <sub>CC</sub> Receiver power supply	7	Tx GND Transmitter ground
3	SD LVTTTL Signal detect	8	Tx EN LVTTTL Transmitter burst mode control, "H": Tx ON
4	RD- Receiver data output- (AC coupled internally)	9	TD+ LVPECL Data input+ (DC coupled and external termination needed)
5	RD+ Receiver data output+ (AC coupled internally)	10	TD- LVPECL Data input- (DC coupled and external termination needed)

## Block Diagram

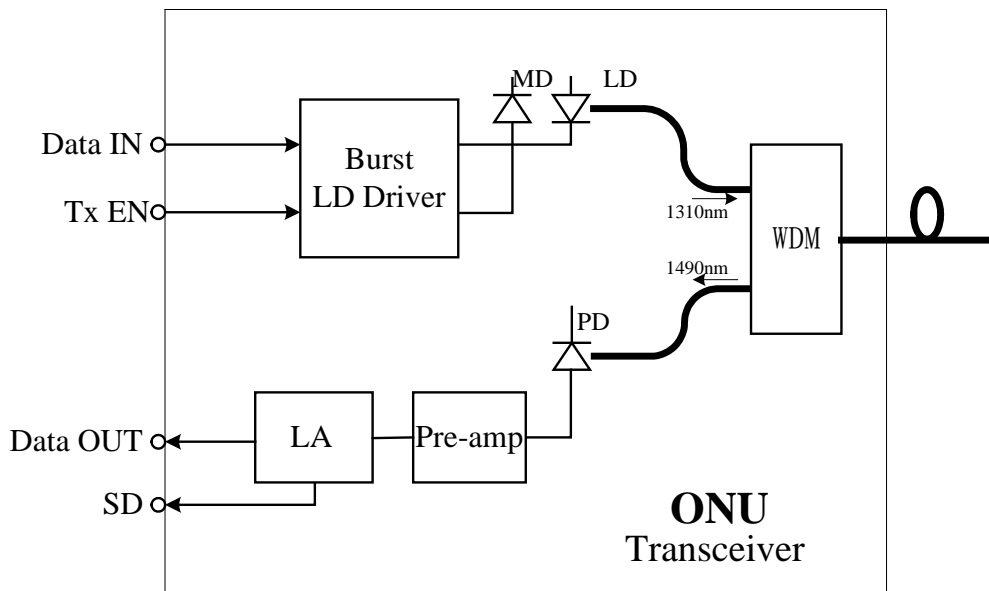

Figure3 Functional block diagram



## Regulatory Compliance

Feature	Test Method	Performance
Electrostatic Discharge (ESD) to the Electrical Pins	MIL-STD-883E Method 3015.7	Class 1 (>1.5kV) – Human Body Model
Electrostatic Discharge (ESD) Immunity	IEC61000-4-2	Class 2 (>4.0kV)
Electromagnetic Interference (EMI)	CISPR22 ITE Class B EN55022 Class B	Compliant with standards
Immunity	IEC61000-4-3 Class 2 EN55024	Typically show no measurable effect from a 3V/m field swept from 80 to 1000MHz applied to the transceiver without a chassis enclosure.
Eye Safety	FDA 21 CFR 1040.10 and 1040.11 UL TUV EN 60825-1	Compliant with Class 1 laser product

## Ordering Information

Part No.	Specification							Application	
	Package	Datarate	Laser	Optical Power	Detector Sensitivity	Temp	Reach	others	Code
RTXM169-404	SFF 2x5	1.25Gb/s	1310nmDFB	0~ +4dBm	PIN+TIA < -25dBm	0~70°C	20km Tx	EN1 1000BASE-PX20	

**Note1:** The "LVTTTL transmitter burst mode control" is set as "Tx Enable at high level "

**Note2:** The length of pigtail is normal 540±40mm (the length of connector is not included ) ,but can be customized for specific requirement.

WTD reserves the right to make changes to the product(s) or information contained herein without notice. No liability is assumed as a result of their use or application. No rights under any patent accompany the sale of any such product(s) or information.

Edition 2009-12-01

Published by Wuhan Telecommunication Devices Co.,Ltd.

Copyright © WTD

All Rights Reserved.