



## GPON ONU Optical Transceiver SFF Module

### RTXM167-406

#### Features

- Integrated Single fiber bi-directional optical subassembly
- 1310nm DFB laser Burst-mode Transmitter and 1490nm APD Continuous receiver(with WDM)
- SFF 2×5 metallic package □ SC/APC connector
- +3.3V single power supply
- Low power consumption
- 0 to 70°C operating ambient temperature
- LVPECL data input
- CML data output
- LVTTTL transmitter burst mode control
- Burst Enable:L-active
- LVTTTL receiver signal-detected indication
- Class 1 Laser eye safety
- Excellent EMI and EMC characteristics
- RoHS Compliant



RTXM167-406

#### Applications

- Optical transceiver for Gigabit-capable Passive Optical Networks (GPON) ONU side

#### Standard

- ITU-T G.984.2 ClassB+
- Small Form Factor Transceiver Multisource Agreement July 5,2000

#### Description

The GPON ONU Transceiver is designed for Gigabit-capable Passive Optical Network □ GPON □ transmission. The module incorporates 1310nm burst-mode transmitter and 1490nm continuous-mode receiver.

The transmitter section uses a 1310nm DFB laser and an integrated BM laser driver which designed to perform very small burst enable/disable delay time. The laser driver also includes digital APC and temperature compensation circuit, which are used for keeping the launch optical power and extinction ratio constant over temperature and aging.

The receiver section uses an integrated 1490nm APD photodiode and preamplifier mounted together. It has the function that indicates receiver signal-detected status (active high).

An integrated WDM coupler can separate 1490nm input light and 1310nm output light.

The metallic package guarantees excellent EMI and EMC characteristics, which totally comply with international relevant standards.

**Absolute Maximum Ratings**

Parameter	Symbol	Unit	Min	Max
Operating Temperature Range	T <sub>c</sub>	°C	0	70
Storage Temperature Range	T <sub>s</sub>	°C	-40	85
Relative Humidity	RH	%	5	95
Power Supply Voltage	V <sub>cc</sub>	V	0	4.6
Pin Input Voltage		V	GND	V <sub>cc</sub>
Receiver Damage Threshold		dBm	+4	-
Lead Solder Temperature		°C	-	260
Lead Solder Duration		S	-	10
Fiber Yield Strength		kgf	-	0.5
Fiber Bend Radius		mm	30	-

**Recommended operating conditions**

Parameter	Symbol	Unit	Min	Typ	Max
Operating Voltage	V <sub>cc</sub>	V	3.13	3.3	3.47
Operating Temperature Range	T <sub>op</sub>	°C	0	-	70

**Specifications(0°C<T<sub>op</sub><70°C and 3.13V<V<sub>cc</sub><3.47V)**

Parameter	Symbol	Unit	Min	Typ	Max	Notes
Electrical Characteristics						
Supply Current	I <sub>cc</sub>	mA	-	-	300	
LVPECL Single Ended Data Input Swing		mV	100	-	800	1
CML Single Ended Data Output Swing		mV	350	-	500	2
Differential Data input impedance		Ω	-	100	-	1
Signal Level(LVTTL H)		V	2.4	-	V <sub>cc</sub>	
Signal Level(LVTTL L)		V	0	-	0.8	
Optical transmitter Characteristics						
Data Rate		Mbps	-	1250	-	
Center Wavelength Range	λ <sub>c</sub>	nm	1280	-	1350	
Spectral Width(@-20dB)	Δλ	nm	-	-	1	
Launch Optical Power	P <sub>o</sub>	dBm	0.5	-	+5	3
Off level light		dBm	-	-	-45	



## RTXM167-406 (V1.0)

Extinction Ratio	EX	dB	10	-	-	4
Burst turn on/off time	Ton/Toff	bit	-	-	16	5
Rise/Fall time(20%~80%)	Tr/Tf	ps	-	-	260	6
RIN <sub>15</sub> OMA		dB/Hz	-	-	-115	
Optical Return Loss Tolerance		dB	-	-	15	
Maximum reflectance		dB	-	-	-12	$\lambda=1.31\mu\text{m}$
Transmitter dispersion penalty	TDP	dB	-	-	1.8	7
Eye Diagram	Compliant with ITU-T G.984.2					8
Optical receive Characteristics						
Data Rate		Mbps	-	2500	-	
Receiver Sensitivity	S	dBm	-	-	-28	9
Overload Input Optical Power	P <sub>in</sub>	dBm	-8	-	-	9
Center Wavelength Range	$\lambda_c$	nm	1480	1490	1500	
Receiver reflectance		dB	-	-	-12	$\lambda=1.49\mu\text{m}$
SD(LVTTL)	Optical Dessert	dBm	-44	-	-	
	Optical Assert		-	-	-30	
LOS Hysteresis		dB	0.5	-	6	

Note1:DC coupled internally and terminated externally (see the recommended circuit below).

Note2: CML output,AC coupled internally (see the recommended circuit below).

Note3: Coupled into 9/125 SMF

Note4: Measured with PRBS 2<sup>23</sup>-1 test pattern @1.25Gbps.

Note5: see Figure 1.

Note6: Measured with the Bessel-Thompson filter ON.

Note7: Transmit on 20km SMF.

Note8: See Figure 2.

Note9: Measured with PRBS 2<sup>23</sup>-1 test pattern @1.25Gbps with Tx on, ER=10dB, BER=10E-12.

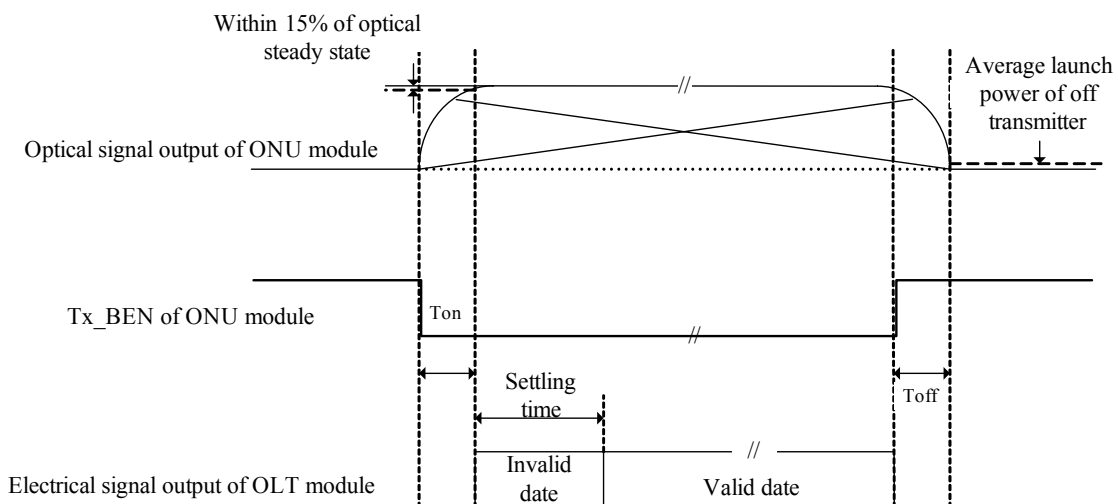

**Figure1 Burst mode Receiver Dynamic range in GPON system**

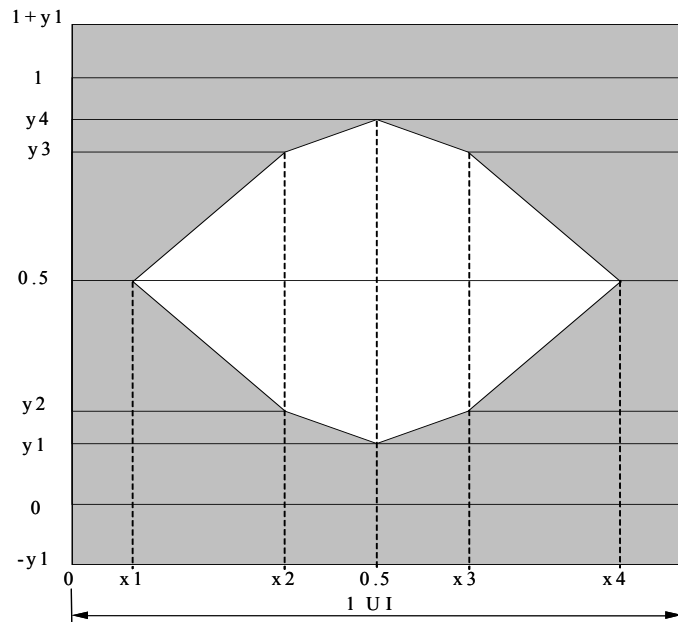

Figure2 Mask of diagram

	155.52 Mbit/s	622.08 Mbit/s	1244.16 Mbit/s	2488.32 Mbit/s
x1/x4	0.10/0.90	0.20/0.80	0.22/0.78	For further study
x2/x3	0.35/0.65	0.40/0.60	0.40/0.60	For further study
y1/y4	0.13/0.87	0.15/0.85	0.17/0.83	For further study
y2/y3	0.20/0.80	0.20/0.80	0.20/0.80	For further study

### Pin Description

Pin	Name	Description	Pin	Name	Description
1	Rx GND	Receiver ground	6	Tx VCC	Transmitter power supply
2	Rx VCC	Receiver power supply	7	Tx GND	Transmitter ground
3	SD	LVTTTL Signal detect	8	Tx DIS	LVTTTL Transmitter burst mode control, "H": Tx OFF
4	RD-	Receiver data output- (AC coupled internally)	9	TD+	LVPECL Data input+ (DC coupled and external termination needed)
5	RD+	Receiver data output+ (AC coupled internally)	10	TD-	LVPECL Data input- (DC coupled and external termination needed)

Block Diagram

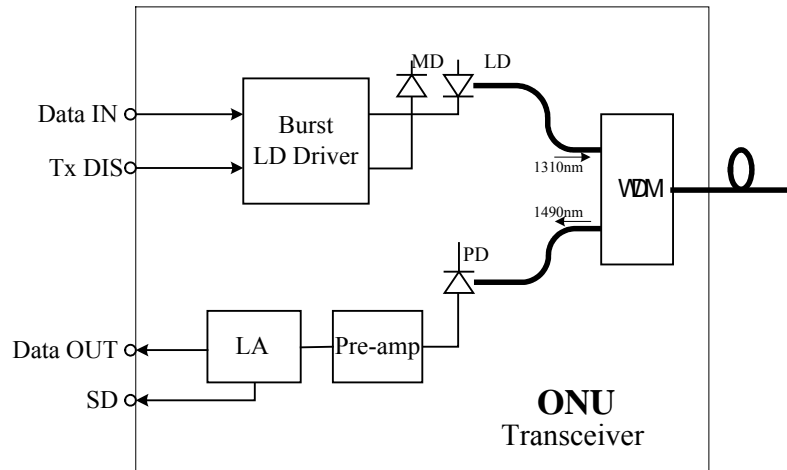
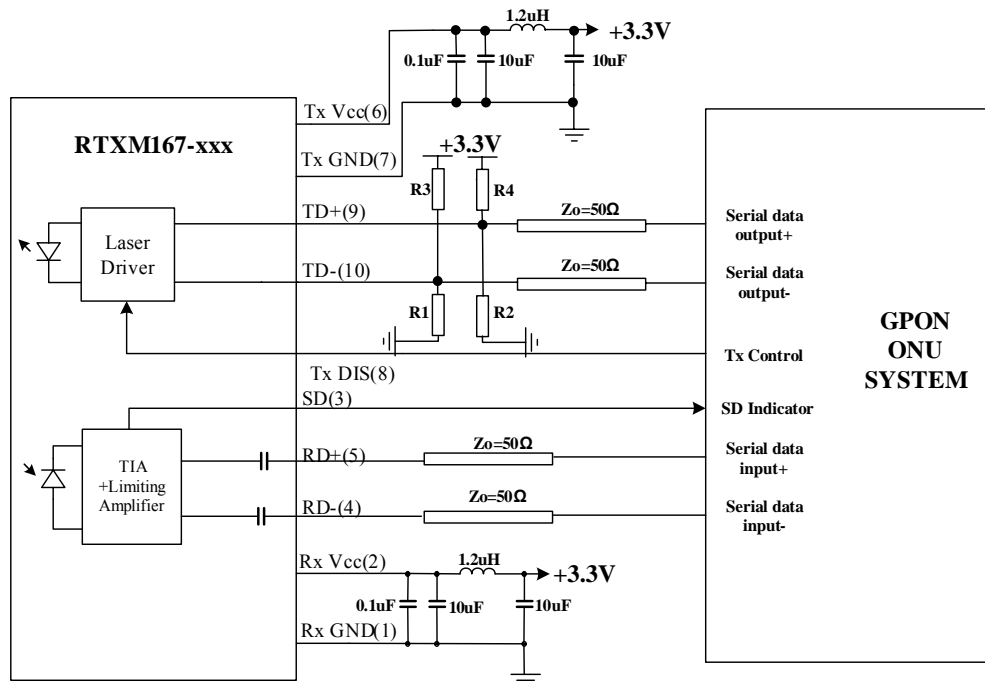

Figure3 Functional block diagram

Typical Application Circuit



$$R1=R2=82\Omega \quad R3=R4=130\Omega$$

Figure4 Typical application circuit



**Package Outline**

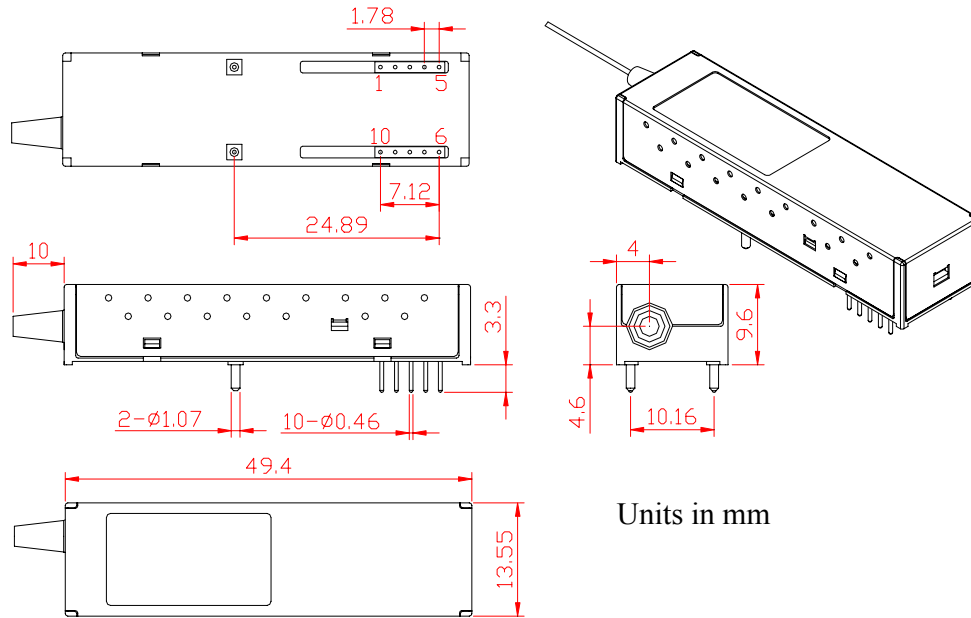

Units in mm

**Figure5 Package outline**

**Regulatory Compliance**

Feature	Test Method	Performance
Electrostatic Discharge (ESD) to the Electrical Pins	MIL-STD-883E Method 3015.7	Class 1 (>1.5kV) – Human Body Model
Electrostatic Discharge (ESD) Immunity	IEC61000-4-2	Class 2(>4.0kV)
Electromagnetic Interference (EMI)	CISPR22 ITE Class B EN55022 Class B	Compliant with standards
Immunity	IEC61000-4-3 Class 2 EN55024	Typically show no measurable effect from a 3V/m field swept from 80 to 1000MHz applied to the transceiver without a chassis enclosure.
Eye Safety	FDA 21 CFR 1040.10 and 1040.11	Compliant with Class 1 laser product
	UL	
	TUV EN 60825-1	



## RTXM167-406 (V1.0)

### Ordering Information

Part No	Specification								Application Code
	Package	Datarate	Laser	Optical Power	Detector	Sensitivity	Top	others	
RTXM167-406	SFF 2×5	1.25Gb/s US 2.5Gb/s DS	1310nm DFB	0.5~ +5dBm	APD	< -28dBm	0~70°C	RoHS	CLASS B+

Note1: BM control logic is "L Enable"

Note2: SC/APC connector. The length of pigtail is normal 1000±30mm(the length of connector is included ) ,but can be customized for specific requirement.

WTD reserves the right to make changes to the product(s) or information contained herein without notice. No liability is assumed as a result of their use or application. No rights under any patent accompany the sale of any such product(s) or information.

Edition 2007-4-10

Published by Wuhan Telecommunication Devices Co.,Ltd.

Copyright © WTD

All Rights Reserved.