



622Mbps SFP transceiver modules without DDM function

RTXM160 Series II

Features

- *Up to 622Mbps data rate*
- *Duplex LC receptacle optical interface*
- *Single +3.3V power supply*
- *Hot-pluggable*
- *AC coupling of PECL signals*
- *Serial ID module on MOD(0-2)*
- *International Class 1 laser safety certified*
- *Transmitter disable input*
- *Receiver Loss of Signal Output*
- *Operating temperature range: -10 °C ~ +70 °C*
- *RoHS Compliant*

Applications

- SDH/ STM-4, SONET/OC-12
- Metropolitan area network
- Other optic link

Standards

- Compliant with SFP MSA (INF-8074i)
- Compliant with ITU-T G.957 STM-4

Absolute Maximum Ratings

Parameter	Symbol	Unit	Min	Max
Storage Temperature Range	T_s	°C	-40	+85
Relative Humidity(without dew)	RH	%	8	80
Supply Voltage	V_{cc}	V	-0.5	4

Recommended Operating Conditions

Parameter	Symbol	Unit	Min	Typ	Max
Case Operating Temperature Range	T_c	°C	-10		70
Power Supply Voltage	V_{cc}	V	3.135	3.3	3.465
Data rate		Mb/s	-	622.08	-

Specifications

(tested under recommended operating condition, unless otherwise noted)

Parameter	Symbol	Min	Type	Max	Units	Notes
Electrical Characteristics						
Supply Current	I_{cc}	-	-	300	mA	1
Transmitter Differential Input Voltage	V_{IN}	300	-	2200	mV _{pp}	
Receiver Differential Output Voltage	V_O	600	-	1200	mV _{pp}	
Transmit Fault (TX_Fault)	V_{OH}	2.0	-	V_{cc}	V	
	V_{OL}	0	-	0.8	V	
Loss of Signal (LOS)	V_{OH}	2.0	-	V_{cc}	V	
	V_{OL}	0	-	0.8	V	
Transmitter Disable (TX-Disable)	V_{IH}	2.0	-	V_{cc}	V	
	V_{IL}	0	-	0.8	V	
MOD-DEF1, 2	V_{IH}	2.0	-	V_{cc}	V	
Optical transmitter Characteristics						
Launched Power(avg.)	P_o	-3	0	+2	dBm	
Output center	L-4.1	λ_c	1274	1310	1356	nm

wavelength	L-4.2		1480	1550	1580	nm	1550nmDFB-LD
Output spectrum width	L-4.1	$\Delta\lambda$	-	-	2.5	nm	
	L-4.2		-	-	1	nm	-20dB(1550nmDFB-LD)
SMSR(dB)			30	-	-		DFB-LD
Extinction ratio		E_R	10	-	-	dB	
Output eye	Compliant with ITU-T G.957 STM-4 eye masks when filtered						
Transmitter jitter		TJ			0.1	UIp-p	2
Relative intensity noise		RIN	-	-	-120	dB/Hz	3
P_{out} TX-Disable Asserted		P_{off}	-	-	-35	dBm	
Optical receiver Characteristics							
Sensitivity		S	-	-30	-28	dBm	4
Overload		P_{in}	-8	-	-	dBm	
Receive reflectance	L-4.2		-	-	-27	dB	
LOS	Optical decreased		-	-45	-	-	dB
	Optical increased		-	-	-29	dB	
LOS hysteresis			-	0.5	3	5	dB

Note1: The supply current includes SFP module's supply current and test board working current.

Note2: For the jitter measurements, the device was driven with SONET OC-12 data pattern with $2^{23}-1$ PRBS payload.

Note3: RIN is the laser noise, integrated over a specified bandwidth, measured relative to average optical power with 12dB return loss.

Note4: Measured with a PRBS $2^{23}-1$ test pattern, @622Mb/s, EX=10dB, BER< 10^{-10} .

Note5: The LOS Hysteresis to minimize "chatter" on the output line. In principle, Hysteresis alone does not guarantee chatter-free operation

Memory Map

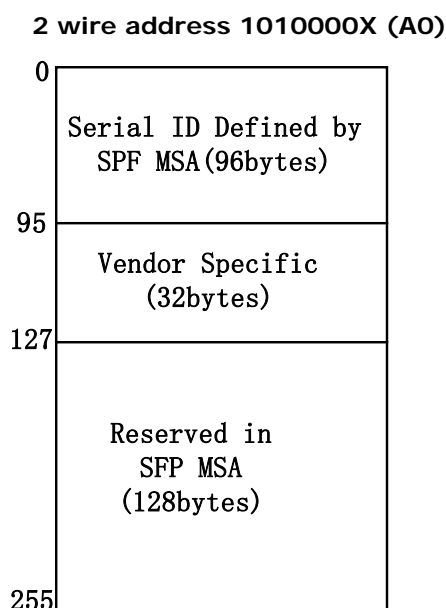

EEPROM Serial ID Memory Contents

Accessing Serial ID Memory uses the 2 wire address 1010000X (A0). Memory Contents of Serial ID are shown in the Table 1.

Table 1 Serial ID Memory Contents

Data Address	Size (Bytes)	Name of Field	Contents(Hex)	Description
BASE ID FIELDS				
0	1	Identifier	03	SFP
1	1	Ext. Identifier	04	SFP function is defined by serial ID only
2	1	Connector	07	LC Connector
3-10	8	Transceiver		Transceiver Codes
11	1	Encoding	03	NRZ
12	1	BR, Nominal	06	622Mbit/s
13	1	Reserved	00	
14	1	Length (9μm) km		Transceiver transmit distance
15	1	Length (9μm) 100m		
16	1	Length (50μm) 10m		
17	1	Length(62.5μm)10m		
18	1	Length (Copper)	00	Not compliant
19	1	Reserved	00	
20-35	16	Vendor name	57 54 44 20 20 20 20 20 20 20 20 20 20 20 20 20	"WTD"(ASCII)
36	1	Reserved	00	
37-39	3	Vendor OUI	00 00 00	
40-55	16	Vendor PN		Transceiver part number
56-59	4	Vendor rev	20 20 20 20	
60-61	2	Wavelength		Transceiver wavelength
62	1	Reserved	00	
63	1	CC_BASE	Check Sum (Variable)	Check code for Base ID Fields
EXTENDED ID FIELDS				
64-65	2	Options	00 1A	TX_DISABLE, TX_FAULT and Loss of Signal implemented.
66	1	BR,max	00	
67	1	BR,min	00	
68-83	16	Vendor SN	42 30 30 39 38 32 32 20 20 20 20 20 20 20 20 20	Serial Number of transceiver (ASCII). For example "B009822".
84-91	8	Date code	30 32 31 30 30 35 20 20	Manufactory date code. For example "021005".
92-94	3	Reserved	00 00 00	
95	1	CC_EXT	Check Sum (Variable)	Check sum for Extended ID Field.

VENDOR SPECIFIC ID FIELDS				
96-127	32	Vendor Specific	Read only	Depends on customer information
128-255	128	Reserved	Read only	Filled by zero

Pin Description

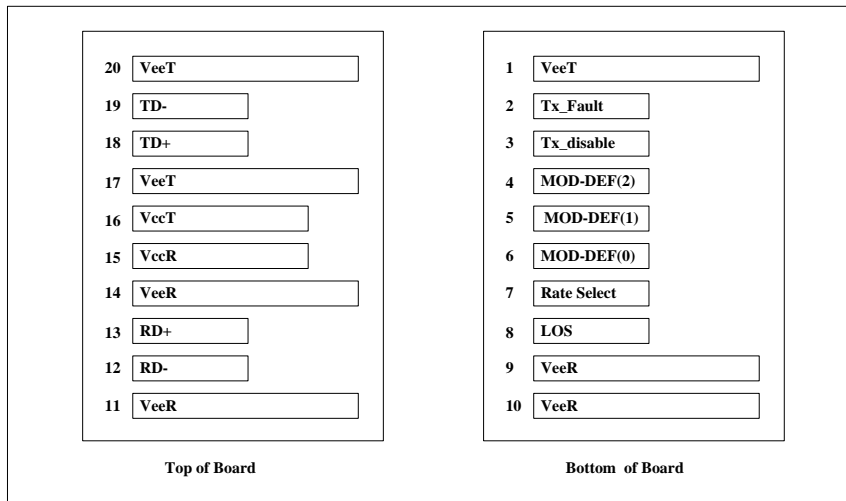

As Viewed Through Top of Board

Pin	Name	Function/Description	Engagement order	Notes
1	VeeT	Transmitter Ground	1	
2	TX Fault	Transmitter Fault Indication	3	1
3	TX Disable	Transmitter Disable-Module disables on high or open	3	2
4	MOD-DEF2	Module Definition 2-Two wire serial ID interface	3	3
5	MOD-DEF1	Module Definition 1-Two wire serial ID interface	3	3
6	MOD-DEF0	Module Definition 0-Two wire serial ID interface	3	3
7	Rate Select	Not Connected	3	
8	LOS	Loss of Signal	3	4
9	VeeR	Receiver Ground	1	
10	VeeR	Receiver Ground	1	
11	Veer	Receiver Ground	1	
12	RD-	Inverse Received Data out	3	5
13	RD+	Received Data out	3	5
14	VeeR	Receiver Ground	1	
15	VccR	Receiver Power — +3.3V±5%	2	6
16	VccT	Transmitter Power — +3.3 V±5%	2	6
17	VeeT	Transmitter Ground	1	
18	TD+	Transmitter Data In	3	7
19	TD-	Inverse Transmitter Data In	3	7
20	VeeT	Transmitter Ground	1	

Note1: TX Fault is open collector/drain output which should be pulled up externally with a 4.7K – 10K Ω resistor on the host board to supply $<V_{ccT}+0.3V$ or $V_{ccR}+0.3V$. When high, this output indicates a laser fault of some kind. Low indicates normal operation. In the low state, the output will be pulled to $<0.8V$.

Note2: TX Disable input is used to shut down the laser output per the state table below. It is pulled up within

the module with a 4.7 – 10K resistor.

- Low (0 – 0.8V): Transmitter on
- Between (0.8V and 2V): Undefined
- High (2.0 – VccT): Transmitter Disabled
- Open: Transmitter Disabled

Note3: Mod-Def 0, 1, 2. These are the module definition pins. They should be pulled up with a 4.7 - 10K resistor on the host board to supply less than VccT+0.3V or VccR+0.3V.

Mod-Def 0 is grounded by the module to indicate that the module is present.

Mod-Def 1 is clock line of two wire serial interface for optional serial ID.

Mod-Def 2 is data line of two wire serial interface for optional serial ID.

Note4: LOS (Loss of signal) is an open collector/drain output which should be pulled up externally with a 4.7 – 10K resistor on the host board to supply <VccT+0.3V or VccR+0.3V. When high, this output indicates the received optical power is below the worst case receiver sensitivity (as defined by the standard in use). Low indicates normal operation. In the low state, the output will be pulled to <0.8V.

Note5: RD-/+: These are the differential receiver outputs. They are AC coupled 100Ω differential lines which should be terminated with 100Ω differential at the user SERDES. The AC coupling is done inside the module and thus not required on the host board.

Note6: VccR and VccT are the receiver and transmitter power supplies. They are defined as 3.3V±5% at the SFP connector pin. The in-rush current will typically be no more than 30mA above steady state supply current after 500ns.

Note7: TD-/+: These are the differential transmitter inputs. They are AC coupled differential lines with 100Ω differential termination inside the module. The AC coupling is done inside the module and is thus not required on host board.

Block Diagram

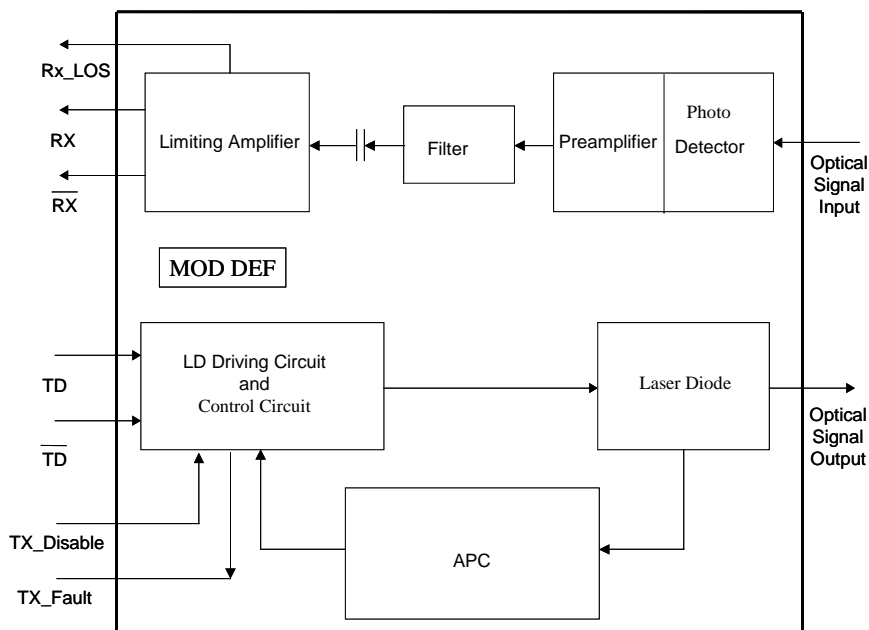

Required Host Board Components

The MSA power supply noise rejection filter is required on the host PCB to meet data sheet performance. The MSA filter incorporates an inductor which should be rated 400mADC and 1Ω serial resistance or better. It should not be replaced with a ferrite. The required filter is illustrated in Figure 3. The MSA also specifies that 4.7K to 10KΩ pull-up resistors for TX_FAULT, LOS, and MOD_DEF0,1,2 are required on the host PCB. Figure is the suggested transceiver/host interface.

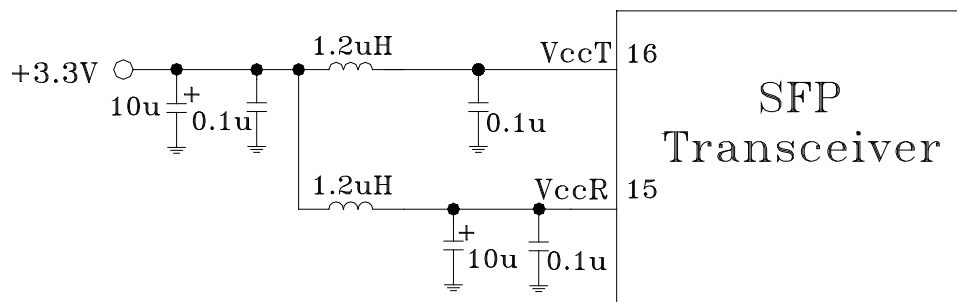

Typical Application Circuit

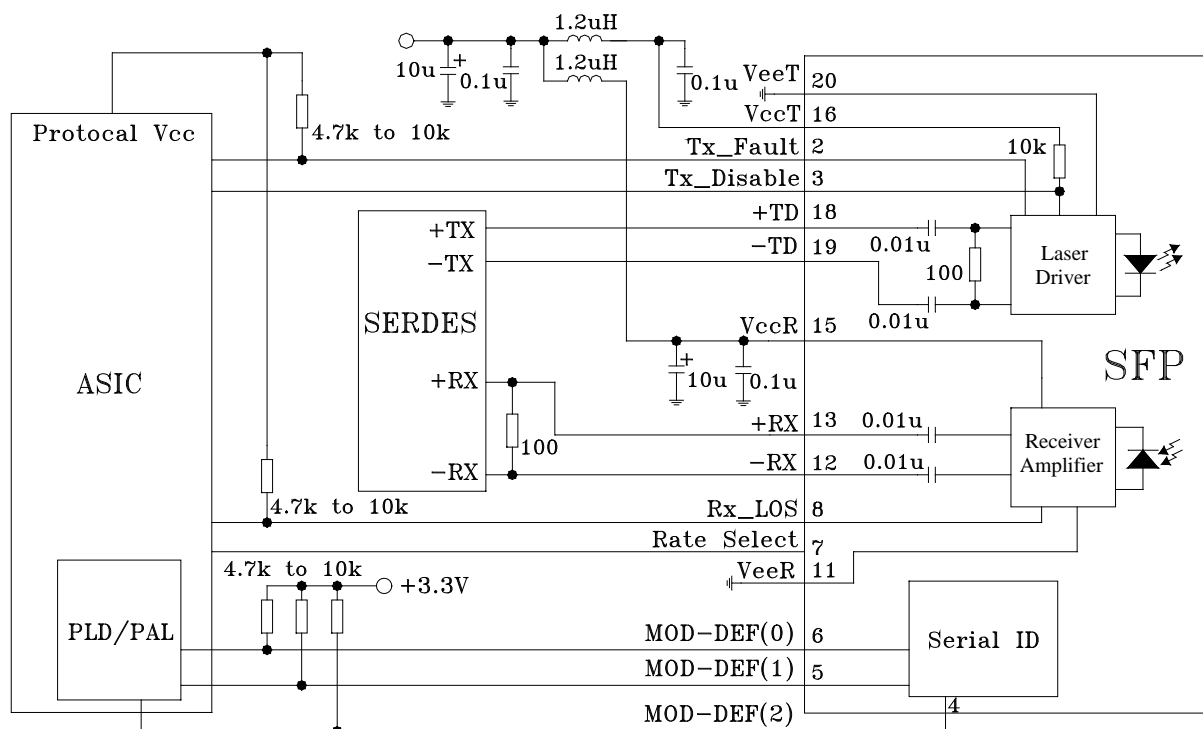

Package Outline

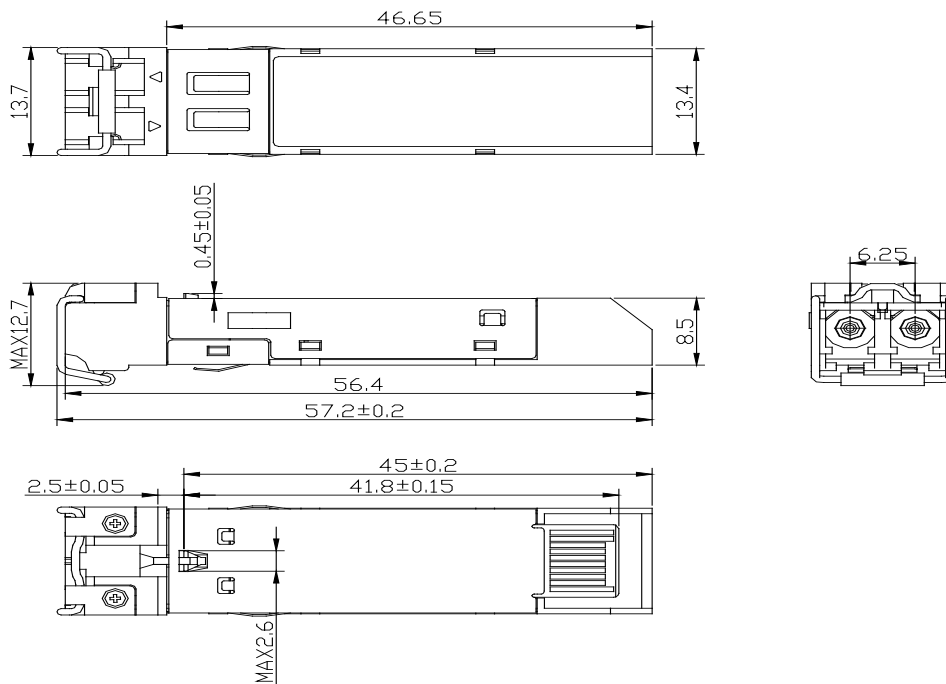

Unit: mm
Unspecified Tolerance: ±0.1mm

PCB Layout Recommendation

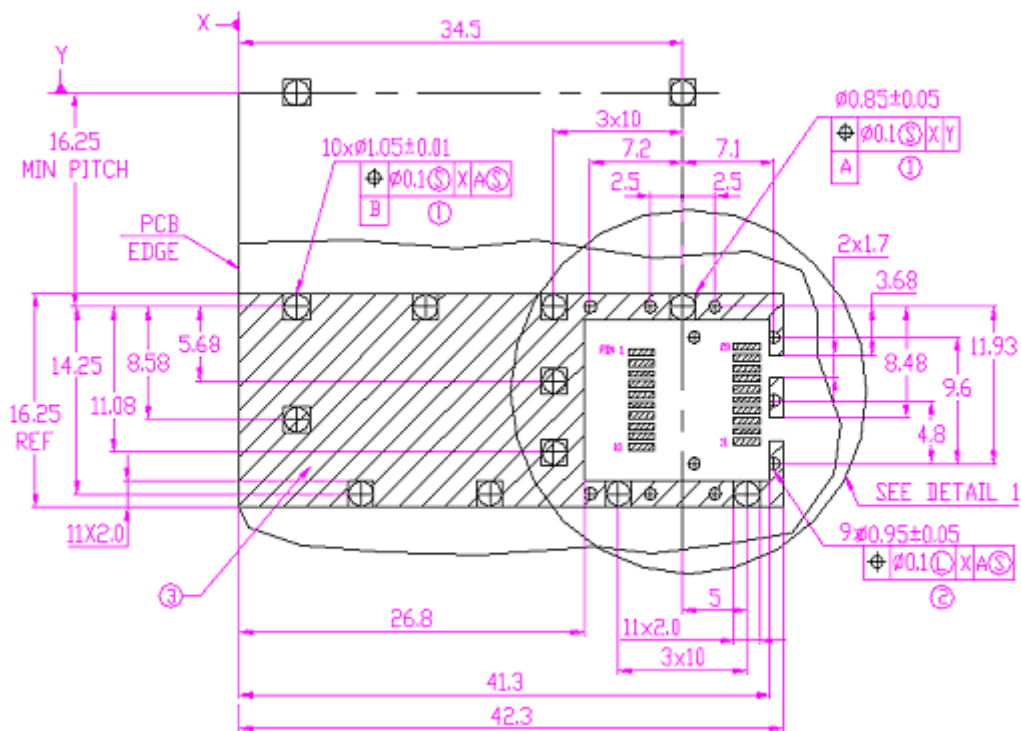

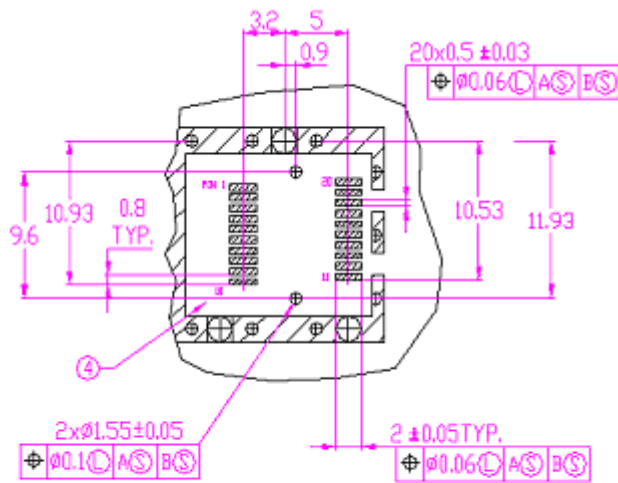

NOTES:

- 1.PADS AND VIAS ARE CHASSIS GROUND.
- 2.THROUGH HOLES,PLATING OPTIONAL.
- 3.HATCHED AREA DENOTES COMPONENT AND TRACE KEEPOUT (EXCEPT CHASSIS GROUND).
- 4.AREA DENOTES COMPONENT KEEPOUT (TRACES ALLOWED).

DIMENSIONS IN MILLIMETERS

DETAIL 1

Regulatory Compliance

Feature	Test Method	Performance
Electrostatic Discharge (ESD) to the Electrical Pins	MIL-STD-883E Method 3015.7	Class 1 (>1.5kV) – Human Body Model
Electrostatic Discharge (ESD) Immunity	IEC61000-4-2	Class 2(>4.0kV)
Electromagnetic Interference (EMI)	CISPR22 ITE Class B FCC Class B CENELEC EN55022 VCCI Class 1	Comply with standard
Immunity	IEC61000-4-3 Class 2	Typically show no measurable effect from a 3 V/m field swept from 80 to 1000MHz applied to the transceiver without a chassis enclosure.
Eye Safety	FDA CDRH 21-CFR 1040 Class 1 NO.:0322110-02 UL NO.:E239070	

Ordering Information

Part. No.	Specifications								Application	
	Pack	Rate	Tx	Pout	Rx	S	Top	Reach others		
RTXM160-401	SFP	622M	1310nm FP	-3 ~ +2dBm	PIN	< -28dBm	-10~70°C	40km	RoHS	SDH L-4.1
RTXM160-501	SFP	622M	1550nm DFB	-3 ~ +2dBm	PIN	< -28dBm	-10~70°C	80km	RoHS	SDH L-4.2

WTD reserves the right to make changes to the product(s) or information contained herein without notice. No liability is assumed as a result of their use or application. No rights under any patent accompany the sale of any such product(s) or information.

Edition 2009-11-24

Published by Wuhan Telecommunication Devices Co.,Ltd.

Copyright © WTD

All Rights Reserved.