



3.3V 1×9 200M Transceiver Module

RTXM135GT-JFC

Features

- *Features*
- *Duplex FC optical interface*
- *Standard 1×9 package*
- *Single +3.3V power supply*
- *0 to 70°C operating temperature range*
- *LVPECL compatible data input/output interface*
- *LVPECL receiver signal-detected indication*
- *Data rate up to 200Mbps*
- *RoHS compliant*

Application

- *SDH/SONET*
- *ATM*

Standard

- *Reference to ITU-T G.957*

Absolute Maximum Ratings

Parameter	Symbol	Unit	Min	Max
Storage Temperature Range	Ts	°C	-40	85
Relative Humidity	RH	%	0	95
Power Supply Voltage	Vcc	V	-0.5	+4.5
Lead Solder Temperature	-	oC	-	260
Lead Solder Duration	-	S	-	10
Voltage on any input/output pin	VI	V	0	Vcc

Recommended Operating Conditions

Parameter	Symbol	Unit	Min	Type	Max
Operating Temperature Range	Top	°C	0	-	70
Power Supply Voltage	Vcc	V	3.14	3.3	3.47
Operating Data Rate		Mbps	-	200	-

Specifications (Top=0 °C to 70°C and VCC=3.13V to 3.47V)

Parameter	Symbol	Unit	Min	Type	Max	Note
Electrical Characteristics						
Supply Current	Icc	mA	-	-	250	
Transmitter Differential Input Voltage	VD	mV	300	-	1860	
Common-mode Input Voltage	Vcom-Vcc	V	-1.38	-	-0.47	
LVPECL Output Voltage-Low	VOL-Vcc	V	-1.810	-	-1.620	1
LVPECL Output Voltage-High	VOH-Vcc	V	-1.025	-	-0.880	1
Optical transmitter Characteristics						
Center Wavelength Range	λ_c	nm	1261	1310	1360	
Launch Optical Power	Po	dBm	-15	-	-8	2
Extinction Ratio	EX	dB	8.2	-	-	
Spectral Width	$\Delta\lambda$	nm	-	-	7.7	
Optical Rise Time	tR	ns	-	-	2.0	3
Optical Fall Time	tF	ns	-	-	2.0	3
Eye Diagram	ITU recommendation G.957 STM-1/OC-3					
Optical receive Characteristics						
Receiver Sensitivity	S	dBm	-	-	-31.0	4
Overload Input Power	Pin	dBm	-8	-	-	4
Signal Detect-Deasserted	PD	dBm	-45.0	-	-	
Signal Detect-Asserted	PA	dBm	-	-	-32.0	
Signal Detect-Hysteresis	PA-PD	dB	0.5	-	6	

Note1: Terminated with 50Ω to Vcc -2V.

Note2: Minimum output optical level is at end of life.

Note3: These are unfiltered 10~90% values.

Note4: Sensitivity and overload for 155M PRBS 223-1 and Bit Error Rate better than or equal to 10E-10.

Pin Description

Pin Name	Level	Description
1	Vee	Negative power of receiver section, normally grounded
2	RD+	LVPECL Data output of receiver section
3	RD-	LVPECL Reverse data output of receiver section
4	SD	LVPECL Optical alarm of receiver section, High level when normal, low level when no light
5	Vcc	Positive power of receiver section, normally +3.3V
6	Vcc	Positive power of transmitter section, normally +3.3V
7	TD-	LVPECL Reverse data input of transmitter section
8	TD+	Data input of transmitter section
9	Vee	Negative power of transmitter section, normally grounded

Typical application circuit

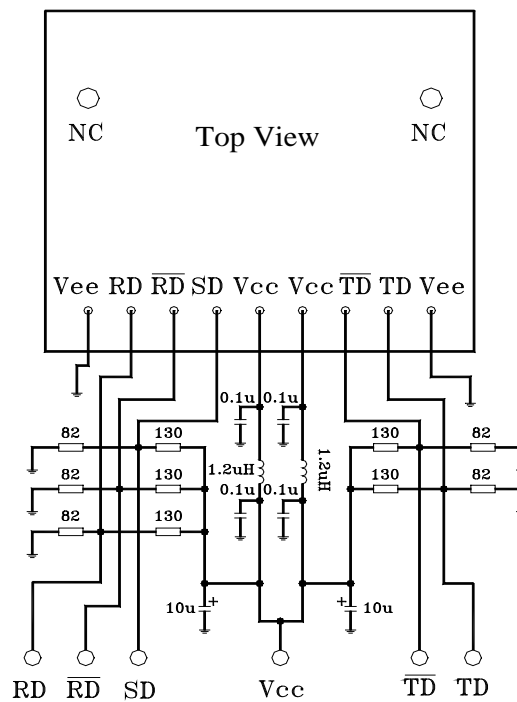

Package Outline (unit:mm)

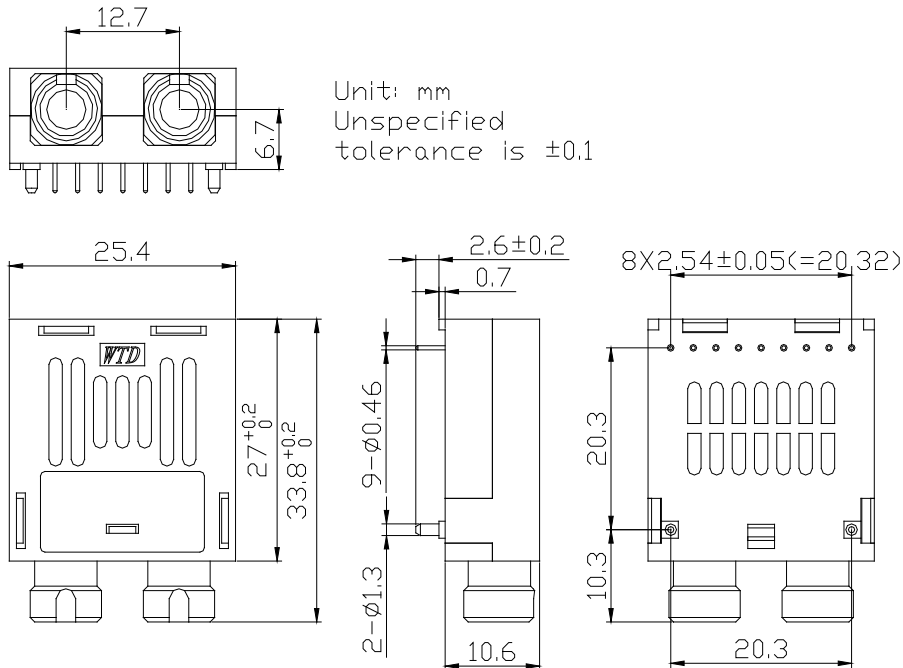

Regulatory Compliance

Feature	Test Method	Performance
Electrostatic Discharge (ESD) to the Electrical Pins	MIL-STD-883E Method 3015.7	Class 1 (>1.5kV) – Human Body Model
Electrostatic Discharge (ESD) Immunity	IEC61000-4-2	Class 2(>4.0kV)
Electromagnetic Interference (EMI)	CISPR22 ITE Class B EN55022 Class B	Compliant with standards
Immunity	IEC61000-4-3 Class 2 EN55024	Typically show no measurable effect from a 3V/m field swept from 80 to 1000MHz applied to the transceiver without a chassis enclosure.
Eye Safety	FDA 21 CFR 1040.10 and 1040.11 UL TUV EN 60825-1	Compliant with Class 1 laser product UL No. E239070

Ordering Information

Part No.	Specification								
	Package	Data rate	Laser	Optical Power	Detector	Sensitivity	Temp	Reach	Interface
RTXM135GT-JFC	1×9 thick type	200Mb/s	1310nm FP-LD	-15~-8dBm	PIN+TIA	-31dBm(max)	0~70°C	15km	Duplex FC

WTD reserves the right to make changes to the product(s) or information contained herein without notice. No liability is assumed as a result of their use or application. No rights under any patent accompany the sale of any such product(s) or information.

Edition 2009-12-01

Published by Wuhan Telecommunication Devices Co.,Ltd.

Copyright © WTD

All Rights Reserved.