



5V 2×9 622Mbps Transceiver Module

RTXM108&118 Series

Features

- Duplex SC receptacle or FC pigtailed optical interface
- 1310nm or 1550nm DFB laser
- Standard 2×9 package
- Single +5V power supply
- 0 to 70°C operating temperature
- range
- PECL compatible data input/output interface
- TTL transmitter laser shutdown
- PECL receiver signal-detected indication

Application

- SDH STM-4 L4.1 and L4.2

Standard

- Compliant with ITU-T G.957

Absolute Maximum Ratings

Parameter	Symbol	Unit	Min	Max
Storage Temperature Range	T_s	°C	-40	85
Relative Humidity	RH	%	0	95
Power Supply Voltage	V_{cc}	V	-0.5	+6
Lead Solder Temperature	-	°C	-	260
Lead Solder Duration	-	S	-	10
Voltage on any input/output pin	V_I	V	0	V_{cc}

Recommended Operating Conditions

Parameter	Symbol	Unit	Min	Typ	Max
Operating Temperature Range	T_{op}	°C	0	-	70
Power Supply Voltage	V_{cc}	V	4.75	5.0	5.25
Operating Data Rate		Mbps	-	622.08	-

Specifications (Top= 0oC to 70oC and VCC=4.75V to 5.25V)

Parameter	Symbol	Unit	Min	Typ	Max	Note
Electrical Characteristics						
Supply Current	I_{cc}	mA	-	-	250	
Transmitter Differential Input Voltage	V_D	mV	500	-	1800	
Common-mode Input Voltage	$V_{com-VCC}$	V	-1.4		-1.19	
PECL Output Voltage-Low	V_{OL-VCC}	V	-1.89	-	-1.6	1
PECL Output Voltage-High	V_{OH-VCC}	V	-1.1	-	-0.9	1
Bias current monitor voltage	B_M	mV		$10 \cdot I_b$	-	
Back facet monitor voltage	P_M	V	0.6	1.2	2.0	
Transmitter disable voltage	-	V	2.0	-	-	
Transmitter enable voltage	-	V	-	-	0.8	
RTXM108D/118D Optical transmitter Characteristics						
Mean Launched power(avg.)	P_o	dBm	-3	-	+2	2
Center wavelength	λ_c	nm	1280	1310	1335	
Spectral Width (-20dB)	$\Delta\lambda$	nm	-	-	1	
Side Mode Suppression Ratio	SMSR	dB	30	-	-	
Extinction ratio	E_R	dB	10	-	-	
Optical Rise Time	t_R	ns			0.5	3
Optical Fall Time	t_F	ns			0.5	3

Eye Diagram		ITU recommendation G.957 STM-4/OC-12				
Optical receiver Characteristics						
Receiver Sensitivity	S	dBm	-	-	-28.0	4
Overload Input Power	P_{in}	dBm	-8.0	-	-	4
Signal Detect-Deasserted	P_D	dBm	-42.0	-	-	
Signal Detect-Asserted	P_A	dBm	-	-	-28.0	
Signal Detect-Hysteresis	$P_A - P_D$	dB	0.5	-	6.0	
RTXM108-DFB/118-DFB Optical transmitter Characteristics						
Mean Launched power(avg.)	P_o	dBm	-3	-	+2	2
Center wavelength	λ_c	nm	1480	1550	1580	
Spectral Width (-20dB)	$\Delta\lambda$	nm	-	-	1	
Side Mode Suppression Ratio	SMSR	dB	30	-	-	
Extinction ratio	E_R	dB	10	-	-	
Optical Rise Time	t_R	ns			0.5	3
Optical Fall Time	t_F	ns			0.5	3
Eye Diagram		ITU recommendation G.957 STM-4/OC-12				
Optical receiver Characteristics						
Receiver Sensitivity	S	dBm	-	-	-28.0	4
Overload Input Power	P_{in}	dBm	-8.0	-	-	4
Signal Detect-Deasserted	P_D	dBm	-42.0	-	-	
Signal Detect-Asserted	P_A	dBm	-	-	-28.0	
Signal Detect-Hysteresis	$P_A - P_D$	dB	0.5	-	6.0	

Note1: Terminated with 50Ω to $V_{CC} - 2V$.

Note2: Minimum output optical level is at end of life.

Note3: These are unfiltered 10~90% values.

Note4: Sensitivity and overload for $2^{23}-1$ PRBS and Bit Error Rate better than or equal to $10E-10$.

Pin Description

Pin	Name	Level	Description
1	NC		Pin not connected
2	NC		Pin not connected
3	NC		Pin not connected
4	NC		Pin not connected
5	BM-		Negative bias current monitor voltage
6	BM+		Positive bias current monitor voltage
7	TxDIS	TTL	Transmitter disable input. A low level switches laser on, a high level switches laser off
8	NC		Pin not connected
9	PM		Back facet monitor voltage. Normally 1.2V

10	V _{EET}	Negative power of transmitter section, normally grounded
11	TD+	PECL Data input of transmitter section
12	TD-	PECL Reverse data input of transmitter section
13	V _{CCT}	Positive power of transmitter section
14	V _{CCR}	Positive power of receiver section
15	SD	PECL Optical alarm of receiver section, High level when normal, low level when no light
16	RD-	PECL Reverse data output of receiver section
17	RD+	PECL Data output of receiver section
18	V _{EER}	Negative power of receiver section, normally grounded

Typical application circuit

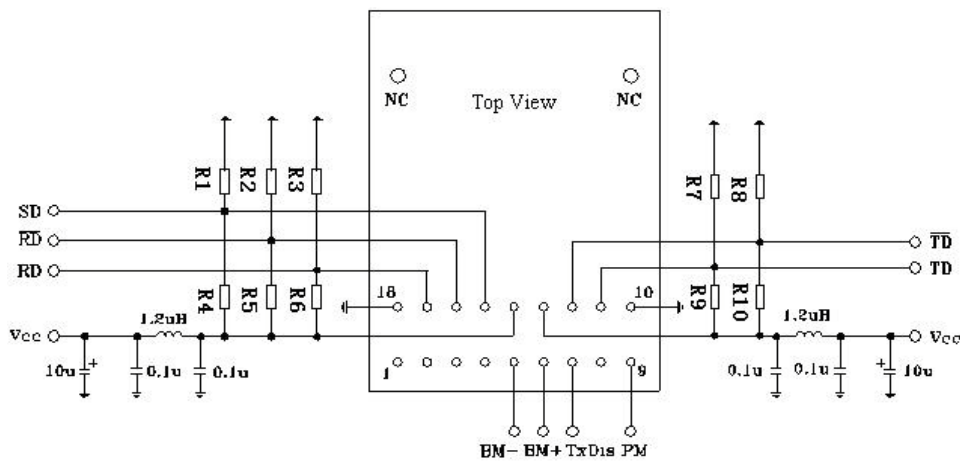

Note: R1=R2=R3=R7=R8=130Ω; R4=R5=R6=R9=R10=82Ω

Package outline (unit: mm)

FC pigtail optical interface

Duplex SC receptacle optical interface

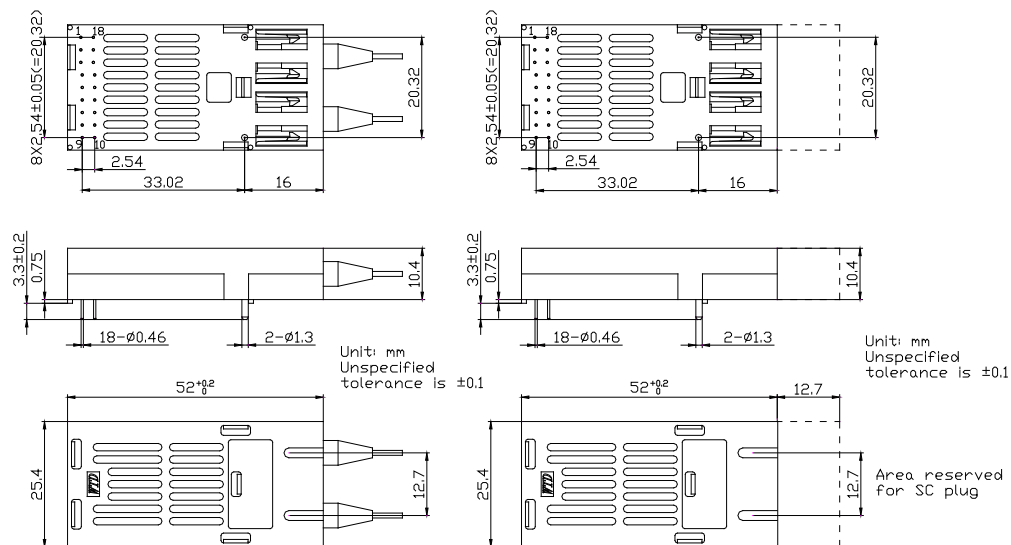

Regulatory Compliance

Feature	Test Method	Performance
Electrostatic Discharge (ESD) to the Electrical Pins	MIL-STD-883E Method 3015.7	Class 1 (>1.5kV) – Human Body Model
Electrostatic Discharge (ESD) Immunity	IEC61000-4-2	Class 2(>4.0kV)
Electromagnetic Interference (EMI)	CISPR22 ITE Class B EN55022 Class B	Compliant with standards
Immunity	IEC61000-4-3 Class 2 EN55024	Typically show no measurable effect from a 3V/m field swept from 80 to 1000MHz applied to the transceiver without a chassis enclosure.
Eye Safety	FDA 21 CFR 1040.10 and 1040.11 <div style="border: 1px solid black; padding: 2px; display: inline-block;">UL</div> TUV EN 60825-1	Compliant with Class 1 laser product UL No. E239070

Ordering information

Part No.	Specification										Application code
	Package	Data rate	Laser	Optical Power	Detector	Sensitivity	Temp	Reach	Interface		
RTXM108D*	2X9	622Mb/s	1310nm DFB-LD	-3~+2dBm	PIN	-28dBm(max)	0~70°C	40km	FC pigtail	SDH L-4.1	
RTXM108-DFB*	2X9	622Mb/s	1550nm DFB-LD	-3~+2dBm	PIN	-28dBm(max)	0~70°C	80km	FC pigtail	SDH L-4.2	
RTXM118D*	2X9	622Mb/s	1310nm DFB-LD	-3~+2dBm	PIN	-28dBm(max)	0~70°C	40km	Duplex SC	SDH L-4.1	
RTXM118-DFB	2X9	622Mb/s	1550nm DFB-LD	-3~+2dBm	PIN	-28dBm(max)	0~70°C	80km	Duplex SC	SDH L-4.2	

*: The product marked with * is not available at present.

WTD reserves the right to make changes to the product(s) or information contained herein without notice. No liability is assumed as a result of their use or application. No rights under any patent accompany the sale of any such product(s) or information.

Edition 2009-12-1

Published by Wuhan Telecommunication Devices Co.,Ltd.

Copyright © WTD

All Rights Reserved.