



5V 2×9 155Mbps Transceiver Module

RTXM106N

Features

- *FC pigtailed optical interface*
- *Standard 2×9 package*
- *Single +5V power supply*
- *-20 to 70oC operating temperature range*
- *PECL compatible data input/output interface*
- *TTL transmitter laser shutdown*
- *PECL receiver signal-detected indication*

Application

- *PDH*

Absolute Maximum Ratings

Parameter	Symbol	Unit	Min	Max
Storage Temperature Range	T_s	°C	-40	85
Relative Humidity	RH	%	0	95
Power Supply Voltage	V_{cc}	V	-0.5	+6
Lead Solder Temperature	-	°C	-	260
Lead Solder Duration	-	S	-	10
Voltage on any input/output pin	V_I	V	0	V_{cc}

Recommended Operating Conditions

Parameter	Symbol	Unit	Min	Typ	Max
Operating Temperature Range	T_{op}	°C	-20	-	70
Power Supply Voltage	V_{cc}	V	4.75	5.0	5.25
Operating Data Rate	-	Mbps	-	52.0	-

Specifications ($T_{op}=-20^{\circ}C$ to $70^{\circ}C$ and $V_{CC}=4.75V$ to $5.25V$)

Parameter	Symbol	Units	Min	Typ	Max	Notes
Electrical Characteristics						
Supply Current	I_{cc}	mA	-	-	250	
Transmitter Differential Input Voltage	V_D	mV	500	-	1800	
Common-mode Input Voltage	$V_{com-VCC}$	V	-1.4	-	-1.19	
PECL Output Voltage-Low	V_{OL-VCC}	V	-1.8	-	-1.6	1
PECL Output Voltage-High	V_{OH-VCC}	V	-1.0	-	-0.8	1
Bias current monitor voltage	B_M	mV		$10 \cdot I_b$		
Back facet monitor voltage	P_M	V	0.6	1.2	2.0	
Transmitter disable voltage	-	V	2.0	-	-	
Transmitter enable voltage	-	V	-	-	0.8	
Optical transmitter Characteristics						
Mean Launched power(avg.)	P_o	dBm	-3	-	0	2
Center wavelength	λ_c	nm	1263	1310	1360	
Spectrum width(RMS)	$\Delta\lambda$	nm	-	-	3.0	
Extinction ratio	E_R	dB	10	-	-	
Optical Rise Time	t_R	ns	-	-	2.0	3
Optical Fall Time	t_F	ns	-	-	2.0	3
Optical receiver Characteristics						
Receiver Sensitivity	S	dBm	-	-	-40	4

Overload Input Power	P_{in}	dBm	-8	-	-	4
Signal Detect-Deasserted	P_D	dBm	-52	-	-	
Signal Detect-Asserted	P_A	dBm	-	-	-40	
Signal Detect-Hysteresis	$P_A - P_D$	dB	0.5	3	6	

Note1: Terminated with 50Ω to $V_{CC} - 2V$.

Note2: Minimum output optical level is at end of life.

Note3: These are unfiltered 10~90% values.

Note4: Sensitivity and overload for 52Mbps/s $2^{23}-1$ PRBS and Bit Error Rate better than or equal to $10E-10$.

Pin Description

Pin	Name	Level	Description
1	NC		Pin not connected
2	NC		Pin not connected
3	NC		Pin not connected
4	NC		Pin not connected
5	BM-		Negative bias current monitor voltage
6	BM+		Positive bias current monitor voltage
7	TxDIs	TTL	Transmitter disable input. A low level switches laser on, a high level switches laser off
8	NC		Pin not connected
9	PM		Back facet monitor voltage. Normally 1.2V
10	V_{EET}		Negative power of transmitter section, normally grounded
11	TD+	PECL	Data input of transmitter section
12	TD-	PECL	Reverse data input of transmitter section
13	V_{CCT}		Positive power of transmitter section
14	V_{CCR}		Positive power of receiver section
15	SD	PECL	Optical alarm of receiver section, High level when normal, low level when no light
16	RD-	PECL	Reverse data output of receiver section
17	RD+	PECL	Data output of receiver section
18	V_{EER}		Negative power of receiver section, normally grounded

Typical application circuit

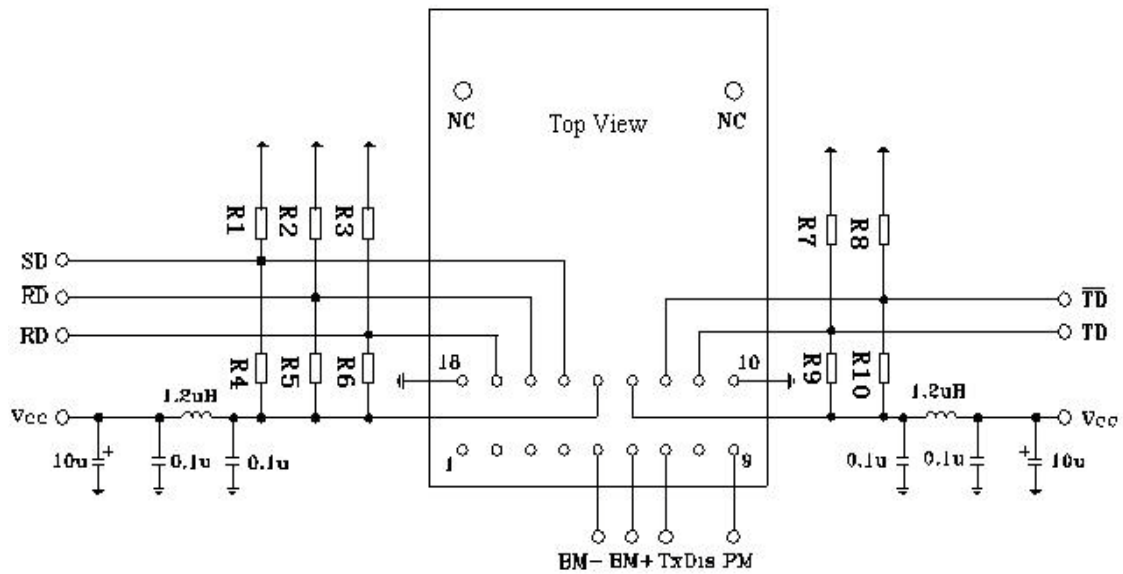

Note: R1=R2=R3=R7=R8=130Ω;R4=R5=R6=R9=R10=82Ω;

Package outline (unit: mm)

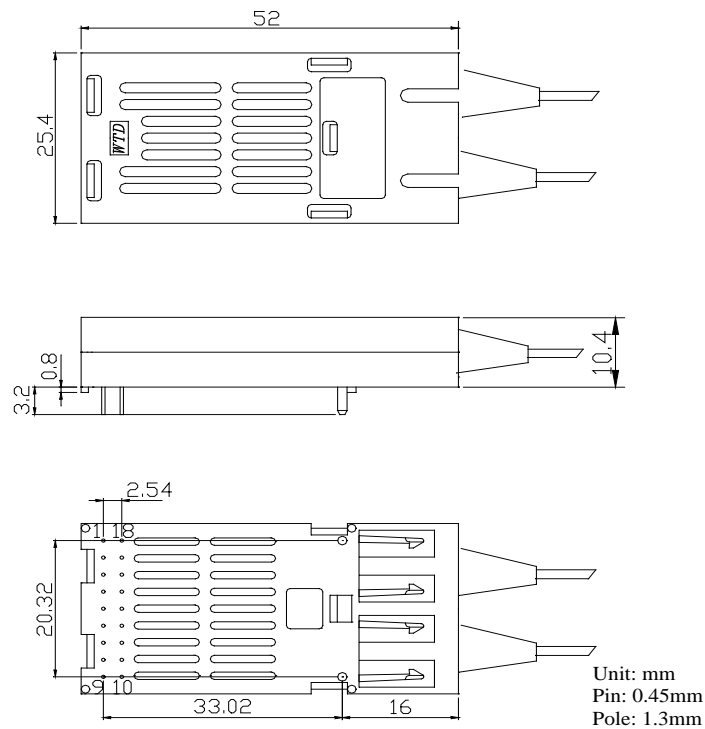

Regulatory Compliance

Feature	Test Method	Performance
Electrostatic Discharge (ESD) to the Electrical Pins	MIL-STD-883E Method 3015.7	Class 1 (>1.5kV) – Human Body Model
Electrostatic Discharge (ESD) Immunity	IEC61000-4-2	Class 2(>4.0kV)
Electromagnetic Interference (EMI)	CISPR22 ITE Class B EN55022 Class B	Compliant with standards
Immunity	IEC61000-4-3 Class 2 EN55024	Typically show no measurable effect from a 3V/m field swept from 80 to 1000MHz applied to the transceiver without a chassis enclosure.
Eye Safety	FDA 21 CFR 1040.10 and 1040.11 <u>UL</u> TUV EN 60825-1	Compliant with Class 1 laser product UL No. E239070

Ordering Information

Part No	Specification								
	Package	Data rate	Laser	Optical Power	Detector	Sensitivity	Temp	Reach	Interface
RTXM106N	2X9	52Mb/s	1310nm FP-LD	-3~0dBm	PIN+TIA	-40dBm(max)	-20~70°C	40km	FC pigtail

WTD reserves the right to make changes to the product(s) or information contained herein without notice. No liability is assumed as a result of their use or application. No rights under any patent accompany the sale of any such product(s) or information.

Edition 2009-12-1

Published by Wuhan Telecommunication Devices Co.,Ltd.

Copyright © WTD

All Rights Reserved.