



5V 2×9 17~25 Mbps Transceiver Module

RTXM106-403

Features

- *1510nm DFB Laser diode transmitter*
- *PIN photodiode receiver*
- *Duplex SC receptacle*
- *+5V Single power supply*
- *Data rate*
- *16.896~25.344Mbps(NRZ)*
- *TTL compatible data input/output interface*
- *TTL Loss of Optical Power Alarm*
- *Compliant with RoHS*
- *RoHS Compliant*

Application

- *DWDM supervisory channel*

Absolute Maximum Ratings

Parameter	Symbol	Unit	Min	Max
Storage Temperature Range	T_s	°C	-40	+85
Relative Humidity	RH	%	5	85
Power Supply Voltage	V_{cc}	V	0	+6
Lead Solder Temperature	T_w	°C	-	380
Lead Solder Duration	W_T	s	-	5
Fiber Yield Strength	-	kgf	-	1
Fiber Bend Radius	-	mm	30	-

Recommended Operating Conditions

Parameter	Symbol	Unit	Min	Typ	Max
Ambient Operating Temperature Range	T_c	°C	0	-	+70
Power Supply Voltage	V_{cc}	V	+4.75	+5.0	+5.25

Specifications

(tested under recommended operating conditions, unless otherwise noted)

Parameter	Symbol	Min	Typ	Max	Units	Notes
Electrical Characteristics						
Operating Voltage	V_{op}	+4.75	+5	+5.25	V	-
Supply Current	I_{cc}	-	-	300	mA	-
Signal Low level	-	-	-	0.8	V	-
Signal High level	-	2.0	-	-	V	-
Bias current monitor voltage	$V_{BM+} - V_{BM-}$	-	$10 \times I_b$	-	mV	-
Transmitter disable voltage	-	2.0	-	V_{cc}	V	-
Transmitter enable voltage	-	0	-	0.8	V	-
Optical transmitter Characteristics						
Data Rate	-	-	20	-	Mbps	-
Launched Power(avg.)	P_o	0	2.5	5	dBm	1
Center Wavelength	λ	1500	1510	1520	nm	
spectrum width	$\Delta\lambda$	-	-	1.0	nm	
Extinction ratio	EX	10	-	-	dB	
Side mode Suppression Ratio	SMSR	30	-	-	dB	
Optical receive Characteristics						
Sensitivity	S	-	-48	-47	dBm	2
Overload	P_{in}	-3	-	-	dBm	

LOS	Optical decreased	P_D	-60	-	-	dBm
	Optical increased	P_A	-	-	-50	dBm
LOS hysteresis		$P_D - P_A$	-	2	-	dB

Note 1: The test condition is PRBS $2^{10}-1$, 20Mbps.

Note 2: The test condition is PRBS $2^{10}-1$, BER= 1×10^{-10} , 20Mbps, 1510nm.

Pin Description

Pin	Name	Level	Description
1,2,3,4	NC	-	Pin not connected
5	BM-	-	Negative bias current monitor voltage
6	BM+	-	Positive bias current monitor voltage
7	TxDis	TTL	Transmitter disable input A low level switches laser on , a high level switches laser off
8	RxP Mon	-	Receiver monitor voltage
9	TxP Mon	-	Transmitter back facet monitor voltage
10	Vee	-	Negative power of transmitter section , normally grounded
11	TD	TTL	Data input of transmitter section
12	NC	-	Pin not connected
13	Vcc	-	Positive power of transmitter section
14	Vcc	-	Positive power of receiver section
15	SD	TTL	Optical alarm of receiver section High level when normal , low level when no light
16	NC	-	Pin not connected
17	RD	TTL	Data output of receiver section
18	Vee	-	Negative power of receiver section, normally grounded

Block diagram

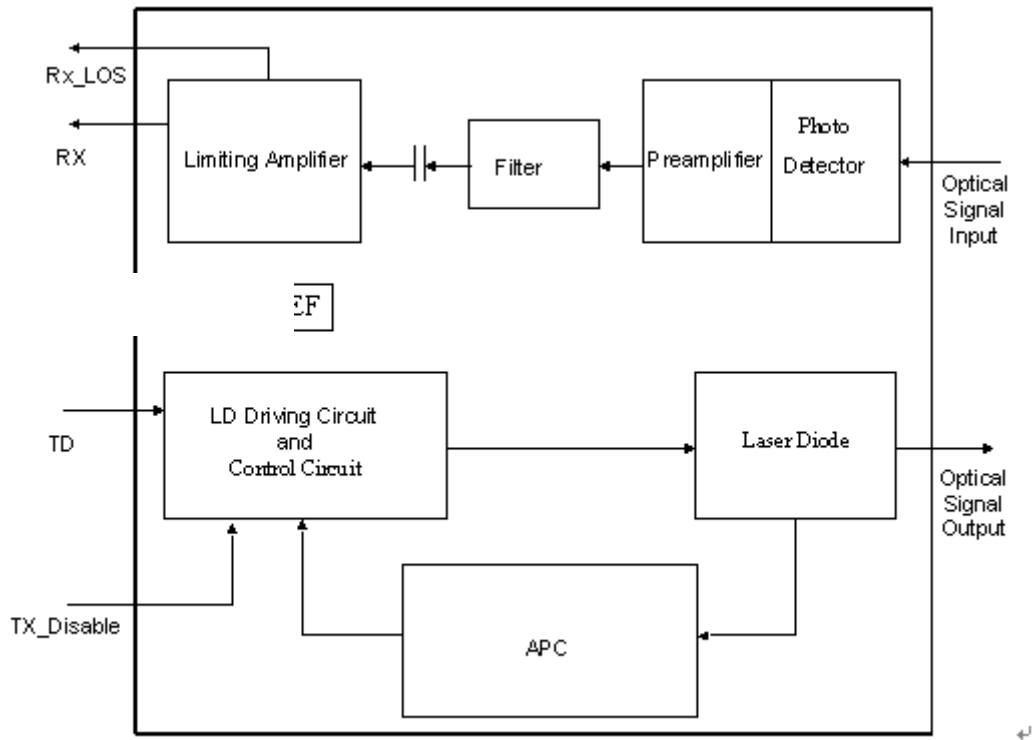

Typical application circuit

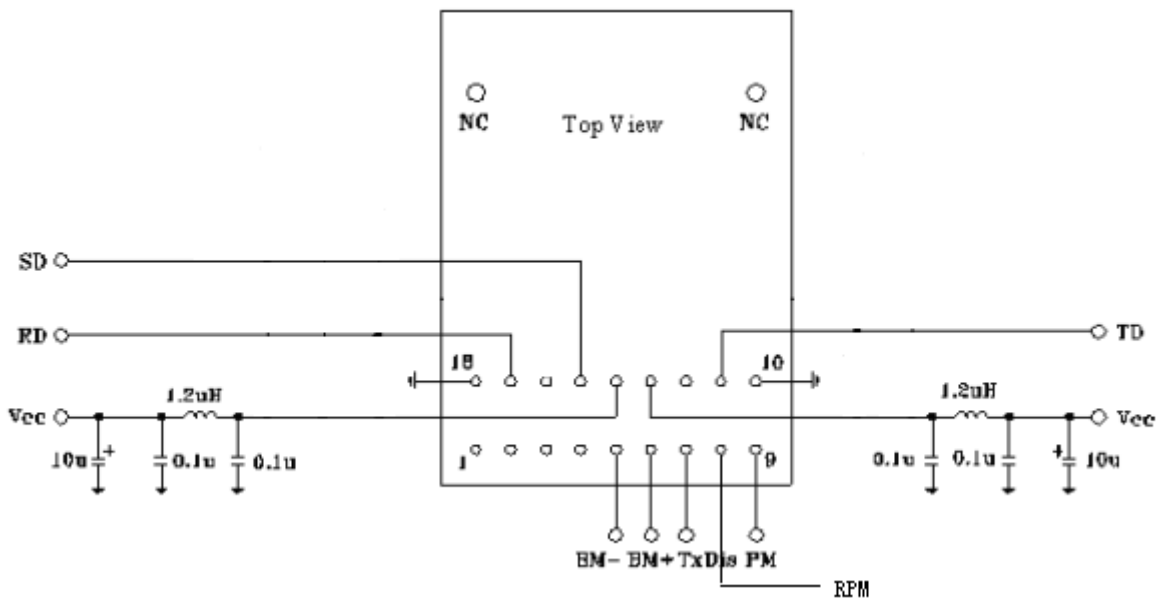

Package outline (unit : mm)

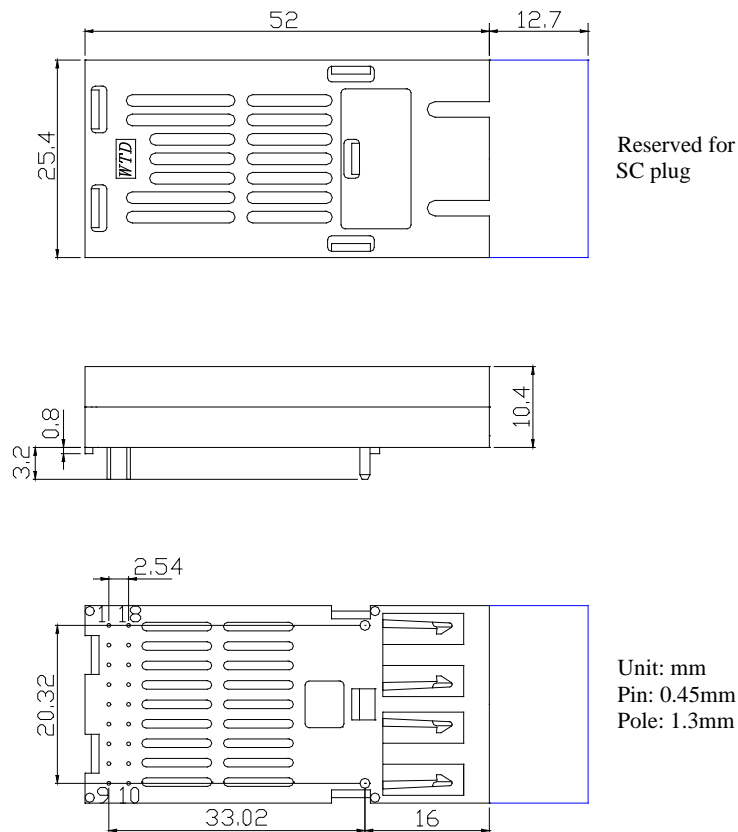

Qualification tests

Feature	Test Method	Performance
Electrostatic Discharge (ESD) to the Electrical Pins	MIL-STD-883D Method 3015.7	Class 1 (>1.5kV) – Human Body Model
Electrostatic Discharge (ESD) Immunity	IEC61000-4-2	Class 2 (>4.0kV)
Electromagnetic Interference (EMI)	CISPR22 ITE Class B FCC Class B CENELEC EN55022 VCCI Class 1	Compliant with standard
Immunity	IEC61000-4-3 Class 2	Typically show no measurable effect from a 10 V/m field swept from 80 to 1000MHz applied to the transceiver without a chassis enclosure.
Eye Safety		FDA CDRH 21-CFR 1040 Class 1 UL

Ordering information

Part No.	Specification								Application	Others
	Package	Datarate	Tx	Pout	Rx	Sensitivity	Top	Reach		
RTXM106-403	2×9	16.896~25.344 Mbps	1510nm DFB	0 ~ +5 dBm	PIN+TIA	< -47dBm	0~70 °C	160km	DWDM; supervisory	SC/PC

WTD reserves the right to make changes to the product(s) or information contained herein without notice. No liability is assumed as a result of their use or application. No rights under any patent accompany the sale of any such product(s) or information.

Edition 2009-12-1

Published by Wuhan Telecommunication Devices Co.,Ltd.

Copyright © WTD

All Rights Reserved.