



## 5V 2×9 155Mbps Transceiver Module

### *RTXM106&116 Series*

---

#### Features

- Duplex SC receptacle or FC pigtailed optical interface
- 1310nm or 1550nm DFB laser
- Standard 2×9 package
- Single +5V power supply
- 0 to 70°C operating temperature
- range
- PECL compatible data input/output interface
- TTL transmitter laser shutdown
- PECL receiver signal-detected indication

#### Application

- SDH STM-1 L1.1 and L1.2
- 100M Fast Ethernet

#### Standard

- Compliant with ITU-T G.957

## Absolute Maximum Ratings

Parameter	Symbol	Unit	Min	Max
Storage Temperature Range	$T_s$	°C	-40	85
Relative Humidity	RH	%	0	95
Power Supply Voltage	$V_{cc}$	V	-0.5	+6
Lead Solder Temperature	-	°C	-	260
Lead Solder Duration	-	S	-	10
Voltage on any input/output pin	$V_I$	V	0	$V_{cc}$

## Recommended Operating Conditions

Parameter	Symbol	Unit	Min	Typ	Max
Operating Temperature Range	$T_{op}$	°C	0	-	70
Power Supply Voltage	$V_{cc}$	V	4.75	5.0	5.25
Operating Data Rate		Mbps	-	155.52	-

## Specifications (Top=0oC to 70oC and VCC=4.75V to 5.25V)

Parameter	Symbol	Unit	Min	Typ	Max	Note
<b>Electrical Characteristics</b>						
Supply Current	$I_{cc}$	mA	-	-	250	
Transmitter Differential Input Voltage	$V_D$	mV	500	-	1800	
Common-mode Input Voltage	$V_{com-VCC}$	V	-1.4		-1.19	
PECL Output Voltage-Low	$V_{OL-VCC}$	V	-1.8	-	-1.6	1
PECL Output Voltage-High	$V_{OH-VCC}$	V	-1.0	-	-0.8	1
Bias current monitor voltage	$B_M$	mV		$10 \cdot I_b$	-	
Back facet monitor voltage	$P_M$	V	0.6	1.2	2.0	
Transmitter disable voltage	-	V	2.0	-	-	
Transmitter enable voltage	-	V	-	-	0.8	
<b>RTXM106D,RTXM116D Optical transmitter Characteristics</b>						
Mean Launched power(avg.)	$P_o$	dBm	-5	-	0	2
Center wavelength	$\lambda_c$	nm	1263	1310	1360	
Spectral Width (-20dB)	$\Delta\lambda$	nm	-	-	1	
Side Mode Suppression Ratio	SMSR	dB	30	-	-	
Extinction ratio	$E_R$	dB	10	-	-	
Optical Rise Time	$t_R$	ns			2.0	3
Optical Fall Time	$t_F$	ns			2.0	3
Eye Diagram	ITU recommendation G.957 STM-1/OC-3					

Optical receiver Characteristics						
Receiver Sensitivity	S	dBm	-	-	-35	4
Overload Input Power	$P_{in}$	dBm	-8	-	-	4
Signal Detect-Deasserted	$P_D$	dBm	-50	-	-	
Signal Detect-Asserted	$P_A$	dBm	-	-	-36.0	
Signal Detect-Hysteresis	$P_A - P_D$	dB	-0.5	-	6.0-	
RTXM106-DFB/116-DFB 1550nm DFB Laser Optical transmitter Characteristics						
Mean Launched power(avg.)	$P_o$	dBm	-5	-	0	2
Center wavelength	$\lambda_c$	nm	1480	1550	1580	
Spectral Width (-20dB)	$\Delta\lambda$	nm	-	-	1	
Side Mode Suppression Ratio	SMSR	dB	30	-	-	
Extinction ratio	$E_R$	dB	10	-	-	
Optical Rise Time	$t_R$	ns			2.0	3
Optical Fall Time	$t_F$	ns			2.0	3
Eye Diagram	ITU recommendation G.957 STM-1/OC-3					
Optical receiver Characteristics						
Receiver Sensitivity	S	dBm	-	-	-35	4
Overload Input Power	$P_{in}$	dBm	-8	-	-	4
Signal Detect-Deasserted	$P_D$	dBm	-50	-	-	
Signal Detect-Asserted	$P_A$	dBm	-	-	-36.0	
Signal Detect-Hysteresis	$P_A - P_D$	dB	-0.5	-	6.0	

**Note1:** Terminated with 50Ω to  $V_{CC} - 2V$ .

**Note2:** Minimum output optical level is at end of life.

**Note3:** These are unfiltered 10~90% values.

**Note4:** Sensitivity and overload for  $2^{23}-1$  PRBS and Bit Error Rate better than or equal to  $10E-10$ .

## Pin Description

Pin	Name	Level	Description
1	NC		Pin not connected
2	NC		Pin not connected
3	NC		Pin not connected
4	NC		Pin not connected
5	BM-		Negative bias current monitor voltage
6	BM+		Positive bias current monitor voltage
7	TxDis	TTL	Transmitter disable input. A low level switches laser on, a high level switches laser off
8	NC		Pin not connected
9	PM		Back facet monitor voltage. Normally 1.2V
10	$V_{EET}$		Negative power of transmitter section, normally grounded

11	TD+	PECL	Data input of transmitter section
12	TD-	PECL	Reverse data input of transmitter section
13	V <sub>CCT</sub>		Positive power of transmitter section
14	V <sub>CCR</sub>		Positive power of receiver section
15	SD	PECL	Optical alarm of receiver section, High level when normal, low level when no light
16	RD-	PECL	Reverse data output of receiver section
17	RD+	PECL	Data output of receiver section
18	V <sub>EEER</sub>		Negative power of receiver section, normally grounded

## Typical application circuit

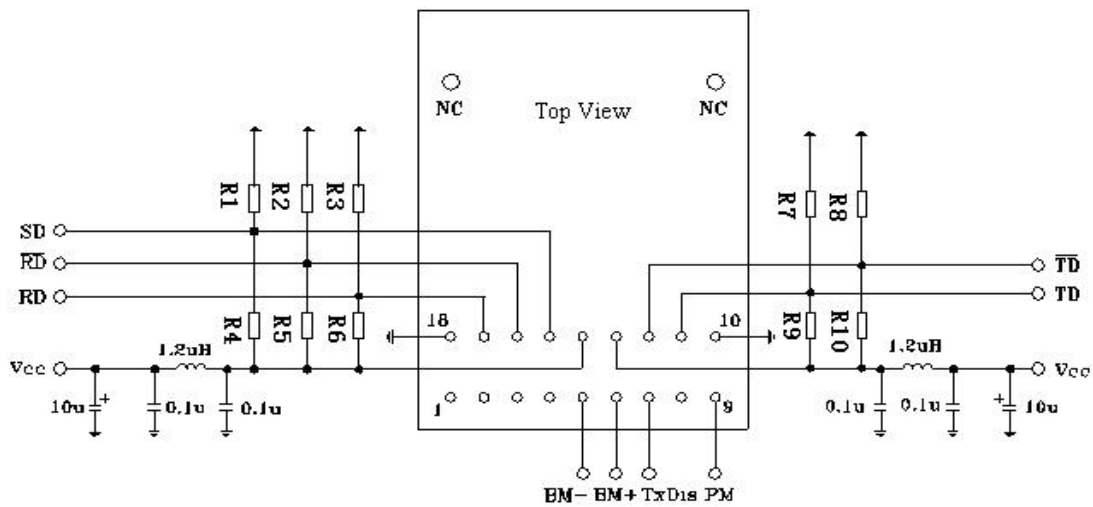

Note: R1=R2=R3=R7=R8=130Ω; R4=R5=R6=R9=R10=82Ω;

## Package outline (unit: mm)

FC pigtail optical interface

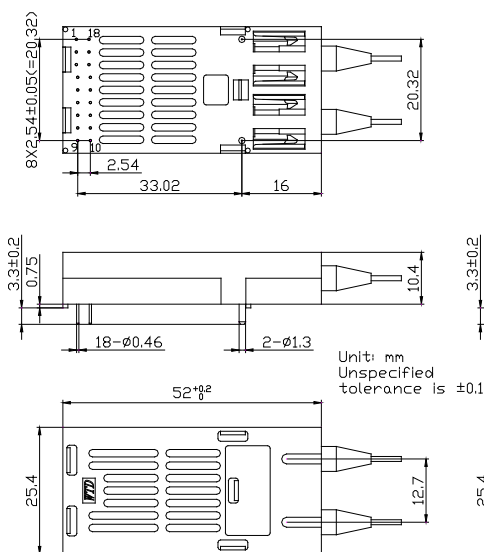

Duplex SC receptacle optical interface

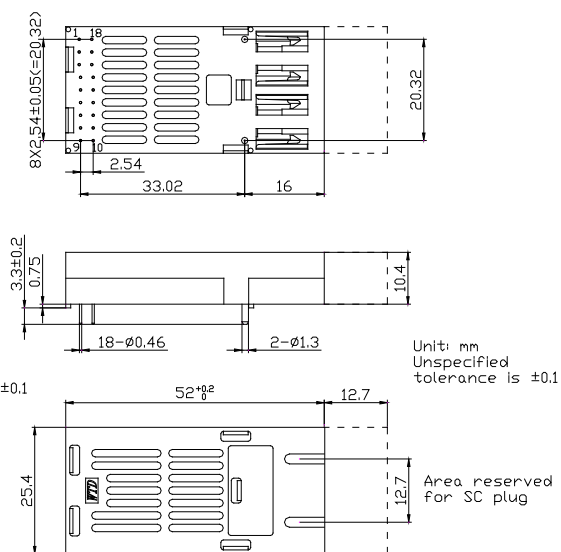

## Regulatory Compliance

Feature	Test Method	Performance
Electrostatic Discharge (ESD) to the Electrical Pins	MIL-STD-883E Method 3015.7	Class 1 (>1.5kV) – Human Body Model
Electrostatic Discharge (ESD) Immunity	IEC61000-4-2	Class 2(>4.0kV)
Electromagnetic Interference (EMI)	CISPR22 ITE Class B EN55022 Class B	Compliant with standards
Immunity	IEC61000-4-3 Class 2 EN55024	Typically show no measurable effect from a 3V/m field swept from 80 to 1000MHz applied to the transceiver without a chassis enclosure.
Eye Safety	FDA 21 CFR 1040.10 and 1040.11 UL TUV EN 60825-1	Compliant with Class 1 laser product UL No. E239070

From datasheet V3.0 to datasheet V3.1

- Revise the parameter "sensitivity" (in "Specifications" table, page2) from "-36dBm" to "-35dBm".

## Ordering Information

Part No.	Specification									Application code
	Package	Data rate	Laser	Optical Power	Detector	Sensitivity	Temp	Reach	Interface	
RTXM106D*	2X9	155Mb/s	1310nm DFB-LD	-5~0dBm	PIN	-35dBm(max)	0~70°C	40km	FC pigtail	SDH L-1.1
RTXM106-DFB	2X9	155Mb/s	1550nm DFB-LD	-5~0dBm	PIN	-35dBm(max)	0~70°C	80km	FC pigtail	SDH L-1.2
RTXM116D*	2X9	155Mb/s	1310nm DFB-LD	-5~0dBm	PIN	-35dBm(max)	0~70°C	40km	Duplex SC	SDH L-1.1
RTXM116-DFB	2X9	155Mb/s	1550nm DFB-LD	-5~0dBm	PIN	-35dBm(max)	0~70°C	80km	Duplex SC	SDH L-1.2

\*: The product marked with \* is not available at present.

WTD reserves the right to make changes to the product(s) or information contained herein without notice. No liability is assumed as a result of their use or application. No rights under any patent accompany the sale of any such product(s) or information.

Edition 2009-12-1

Published by Wuhan Telecommunication Devices Co.,Ltd.

Copyright © WTD

All Rights Reserved.